

VERSA STEEL Approval Drawings

WATER RESERVOIR SECURITY HATCH, ST, NO SKIRT, SERIES 48 X 48

Assembly No.:VSH-200-A-48-48-STN-GS

ASSEMBLY NO./PART NUMBER KEY:

VSH= VERSA STEEL INC. HATCH
 200 = 200 P.S.F. RATED
 A= ALUMINUM CONSTRUCTION
 48-48= SIZE INTERIOR OPENING
 STN = SINGLE TEE FRAME SERIES, NO SKIRT
 NS= NO GAS SPRING

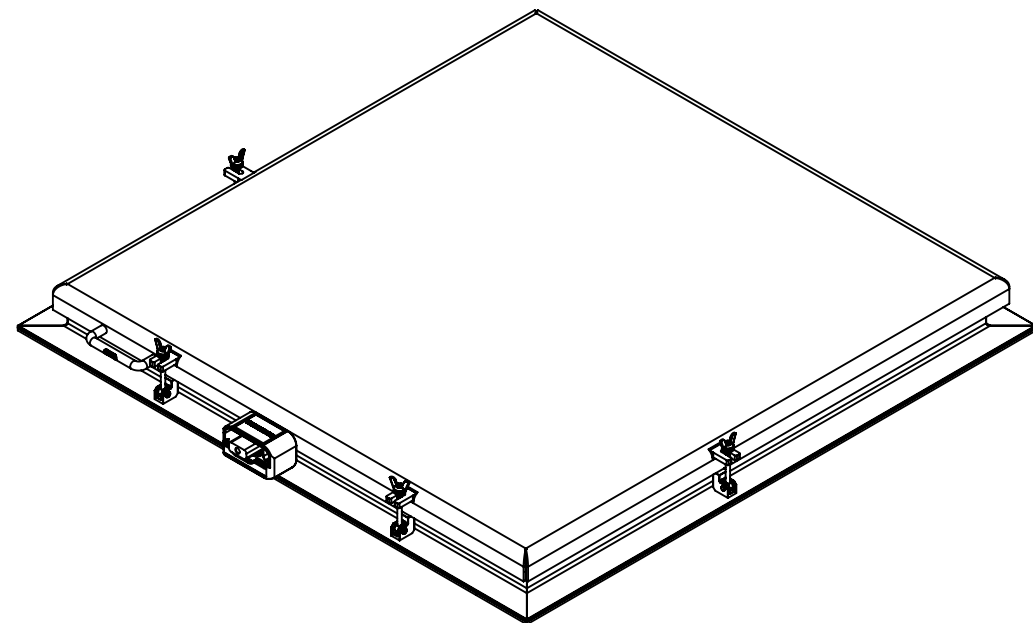

GENERAL SPECIFICATIONS:

1. UNIT IS WEATHER PROOF WITH CONTINOUS BULB SEAL ON LID TO FRAME AND 1/4" X 5-1/4" WIDE FRAME TO CURB SEALS.
2. LID OVER LAPS FRAME A MINIMUM OF 2 INCHES.
3. FRAME IS A MINIMUM OF 4" ABOVE THE CURB.
4. LID IS HINGED ON SIDE WITH TAMPER PROOF SCREWS AND PROVISION FOR A PADLOCK WITH TAMPER PROOF COVER. THERE ARE A MINIMUM OF FOUR SWING BOLT HOLD DOWNS TO SECURE THE HATCH FOR WEATHER PROOF SEAL.
5. HATCH IS DESIGNED FOR 200 P.S.F. LOAD.
6. THERE ARE 8 INTERIOR ATTACHMENT POINTS FOR SECURITY USING 1/2" FASTENER. THERE IS A FULL FACE GASKET OF 5-1/4" WIDE CLOSED CELL FOAM EPDM BETWEEN FRAME AND CURB.
7. LID IS A 1/4" 5086 ALUMINUM PLATE.
8. ALL FASTENERS AND HARDWARE ARE 316 STAINLESS STEEL.

THIS DOCUMENT CONTAINS PROPRIETARY, TRADE SECRET INFORMATION THAT IS THE PROPERTY OF VERSA STEEL, INC. THE INFORMATION CONTAINED IN THIS DOCUMENT, INCLUDING THE PRINCIPLE OF DESIGN, MAY NOT BE USED OR COPIED, IN WHOLE OR IN PART, WITHOUT THE EXPRESS PRIOR WRITTEN CONSENT OF VERSA STEEL, INC.

MATERIAL		6061-T6 ALUMINUM	
FINISH		BARE	
SHEET TITLE		PART NUMBER: VSH-200-A-48-48-STN-GS	
PART NUMBER		VSH-200-A-48-48-STN-GS	
SUPPLIER		FABRICATED PART	
SCALE		1:16	
DRAWING NO.		VSH-200-A-48-48-STN-GS-AP	
REVISION NO.		C	
SHEET NO.		1 OF 4	
REV	ISSUED FOR	DATE	BY
G			
F			
E			
D			
C			
B			
A			

VERSA STEEL, INC.
 1618 NE FIRST AVENUE
 PORTLAND, OREGON 97232
 (503)287-9822
 FAX (503)-287-7483

DRAWN BY
 E. BAILIFF
 DATE
 2020-11-25
 CHECKED BY

APPROVED BY

WATER RESERVOIR SECURITY HATCH, ST, NO SKIRT, SERIES 48 X 48

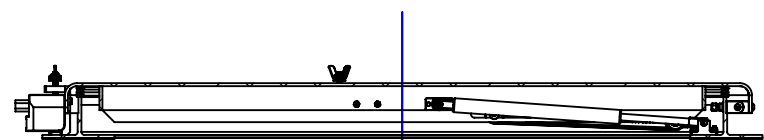
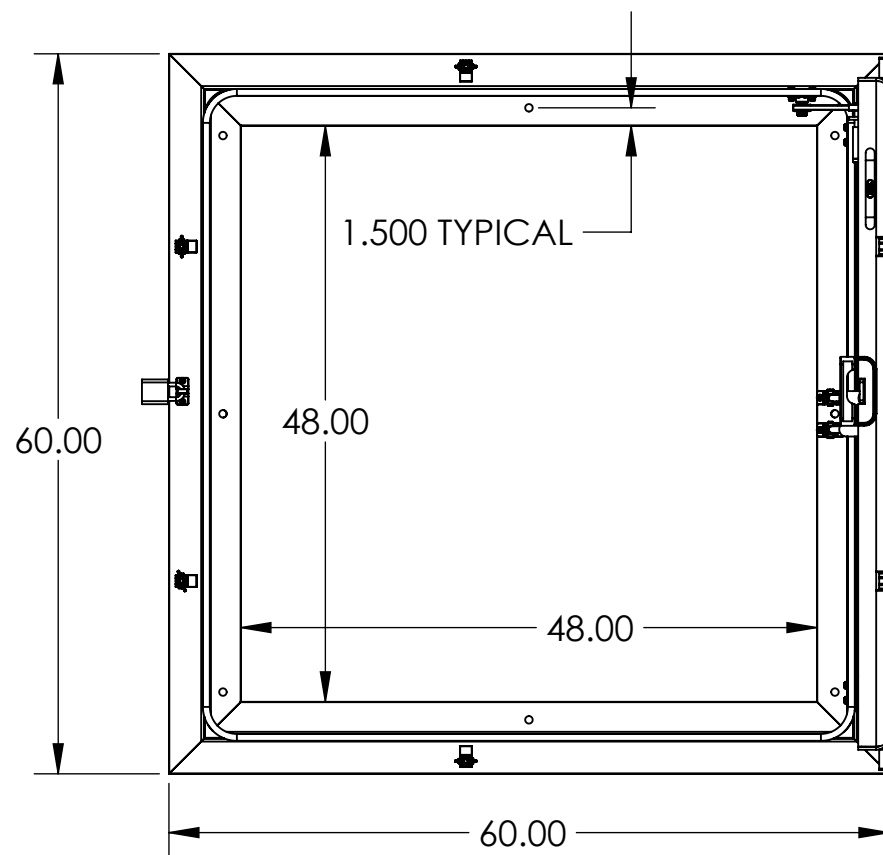
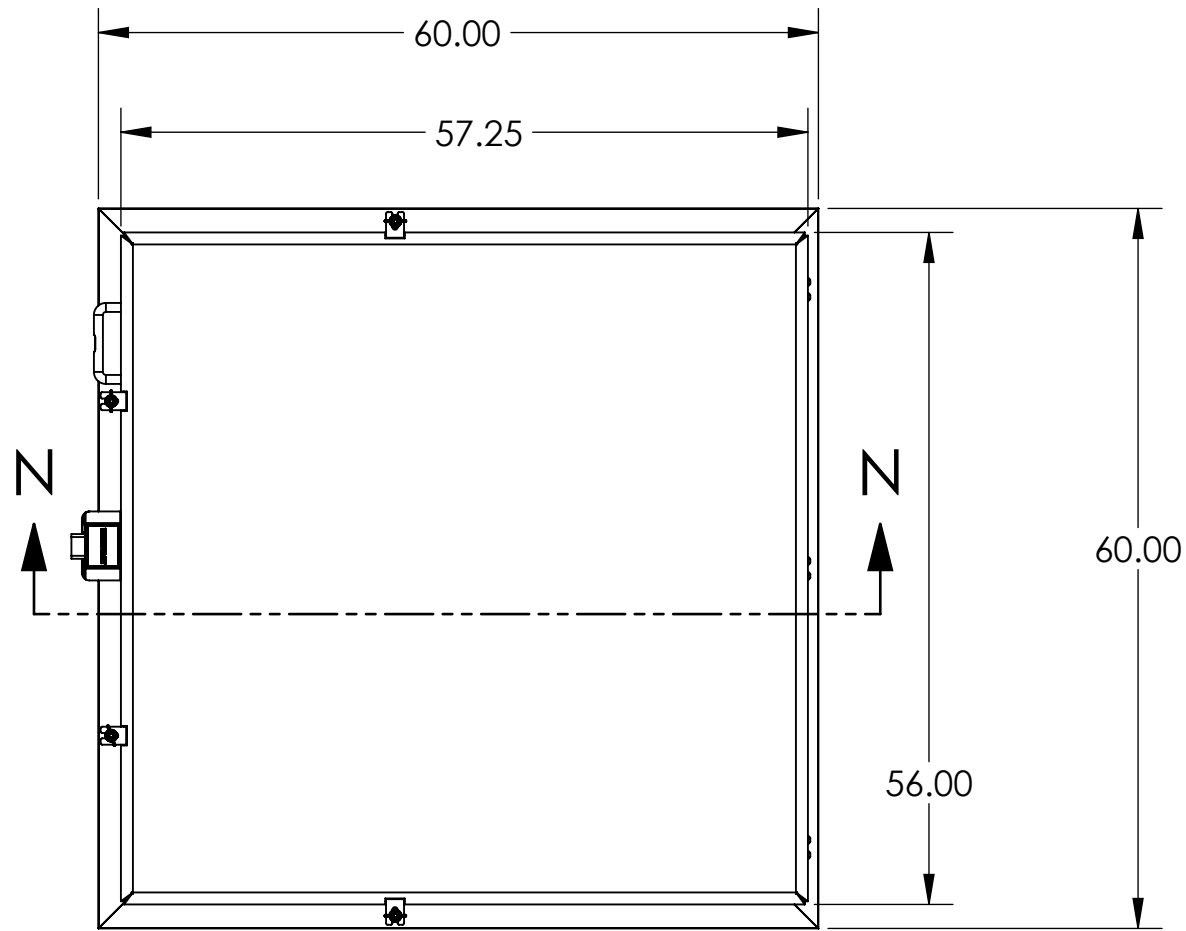

SECTION N-N

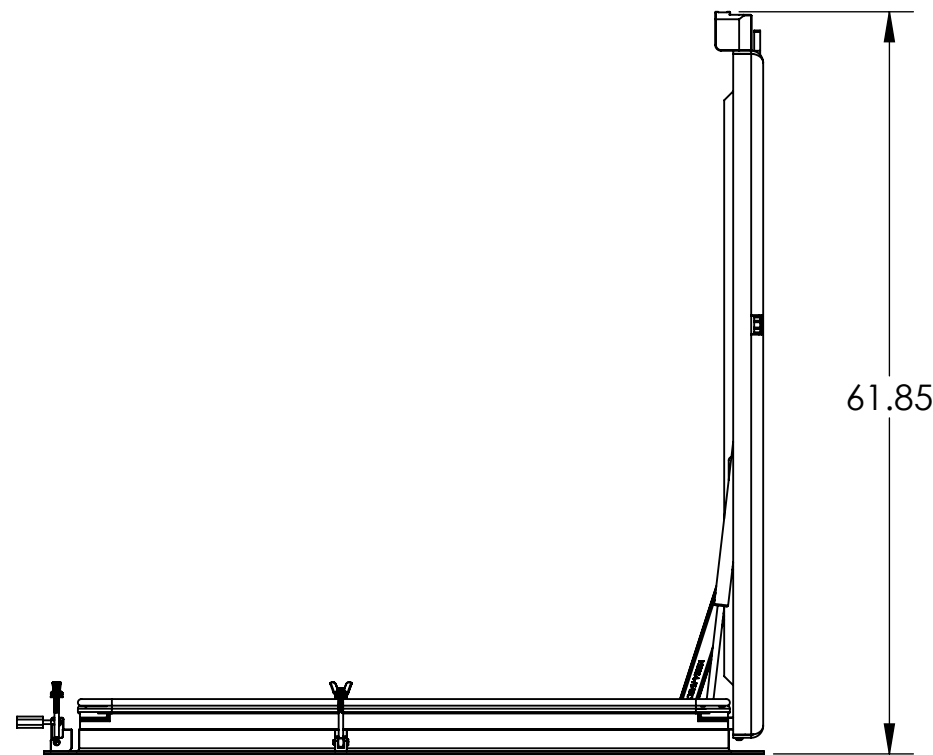
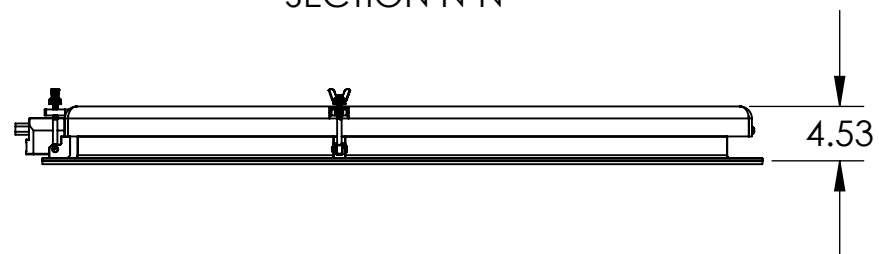

NOTES:
 PN: VSH-200-A-48-48-STN-GS
 DESC: WATER RESERVOIR SECURITY HATCH, ST, NO SKIRT, SERIES 48 X 48
 MATRL: 6061-T6 ALUMINUM
 EST. WT: 186.9
 FINISH: BARE
 NOTE: -
 CAD FILE: VSH-200-A-48-48-STN-GS-APPROVAL

THIS DOCUMENT CONTAINS PROPRIETARY, TRADE SECRET, PROPRIETARY INFORMATION THAT IS THE PROPERTY OF VERSA STEEL, INC. THE INFORMATION CONTAINED IN THIS DOCUMENT, INCLUDING THE PRINCIPLE OF DESIGN, MAY NOT BE USED OR COPIED, IN WHOLE OR IN PART, WITHOUT THE EXPRESS PRIOR WRITTEN CONSENT OF VERSA STEEL, INC.

MATERIAL	6061-T6 ALUMINUM		
FINISH	BARE		
SHEET TITLE	WATER RESERVOIR SECURITY HATCH, ST, NO SKIRT, SERIES 48 X 48		
PART NUMBER	VSH-200-A-48-48-STN-GS		
SUPPLIER	FABRICATED PART		
SCALE	1:16		
DRAWING NO.	VSH-200-A-48-48-STN-GS-AP		
REVISION NO.	C		
SHEET NO.	2 OF 4		
REV	ISSUED FOR	DATE	BY
G			
F			
E			
D			
C			
B			
A			

VERSA STEEL, INC.
 1618 NE FIRST AVENUE
 PORTLAND, OREGON 97232
 (503)287-9822
 FAX (503)-287-7483

DRAWN BY
 E. BAILIFF
 DATE
 2020-11-25
 CHECKED BY

APPROVED BY

PART NUMBER: VSH-200-A-48-48-STN-GS

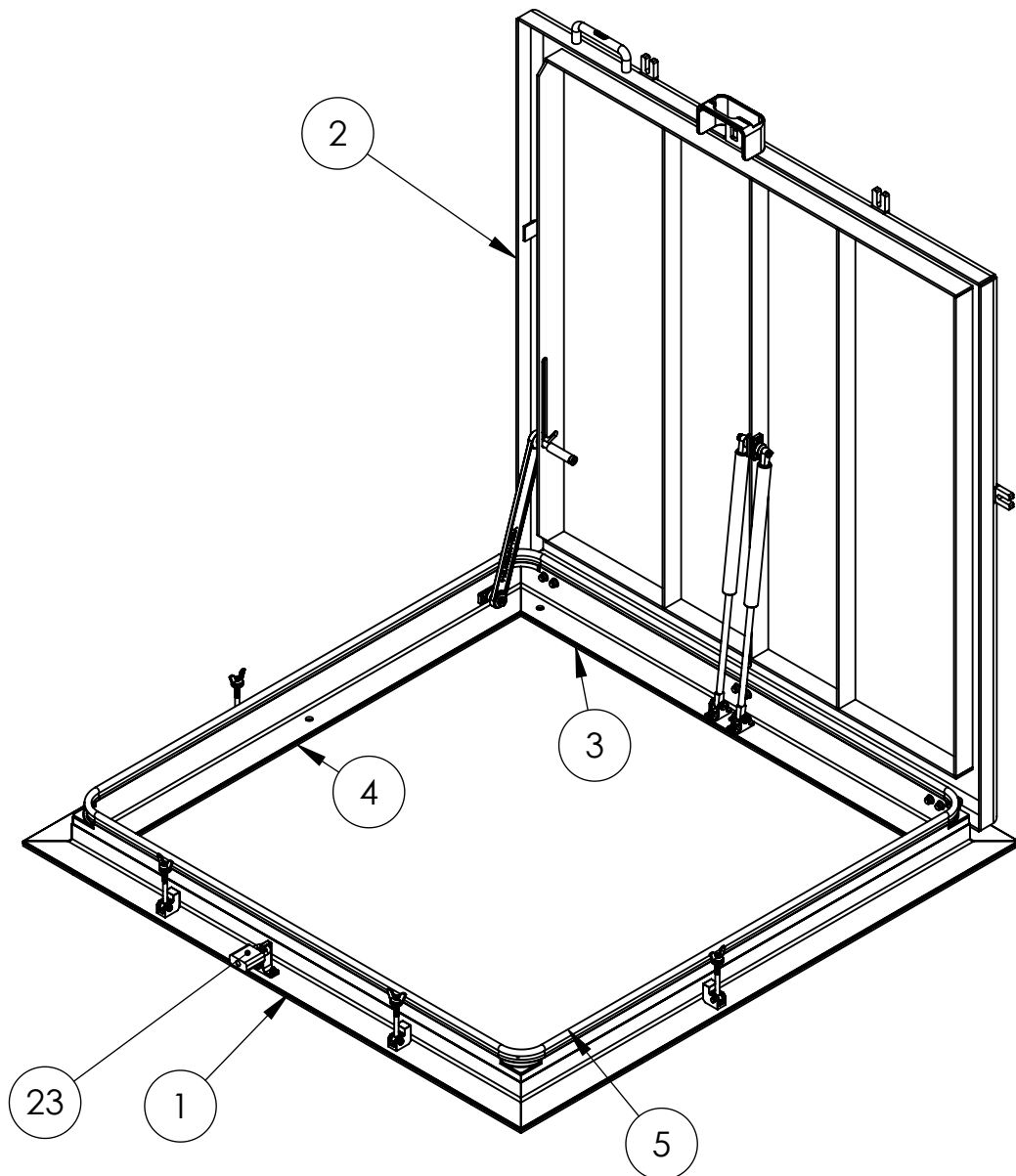

SEE SHEET 4 FOR DETAIL CALLOUTS

ITEM NO.	PART NUMBER	DESCRIPTION	QTY
1	7000660-48X48-STN	T-FRAME, SKIRT 48 X 48	1
2	7000649-48X48	LID WELDMENT, T-FRAME 48 X 48	1
3	1001725-48	SEAL, BASE WIDTH 48	2
4	1001726-48	SEAL, BASE SIDE 48	2
5	1000559-48X48	HATCH SEAL, 48 X 48	1
6	1165-10-300-FO-C2C2	STAINLESS STEEL GAS SPRINGS, 10" STROKE, 300 LBS	2
7	1000756	Clevis Pin 3/8x1-1/4	2
8	VS-37	.375 Dia External, single turn, retaining ring-T316	6
9	1000656	Shoulder Bolt 1/2x5/8	1
10	1000657	Shoulder Bolt 3/8x 1/2	2
11	C6LB-U12-6	LOCK BOLT STAINLESS 3/8" DIA (1/4" TO 1/2" GRIP RANGE)	6
12	3LC-2CU-12	HUCK LOCKING COLLAR, 3LC, 3/8", STAINLESS	6
13	1000793-06	SRING LOCK WASHER, 3/8", 316	4
14	1000792-06	WASHER, 3/8" 316, WIDE	4
15	1000059	ROD END 3/8" ID X 3/4" OD X 4 1/2" LG W/ 3/8-16 THRD X 2" LG	4
16	1000061	WING NUT, 3/8-16 UNC	4
17	1000664	Clevis Pin 3/8x1	4
18	GFI-0809-08	FLANGED BEARING	1
17	9446K71	LOCK BAR COVERING, GP PVC TUBING, RED	1
20	1000060	SH SHOULDER SCREW, 3/8"-16 X 1/2" X 4.0 LG 316	1
21	1000524-24	3/4" HOLD OPEN ARM, 24, 316 SST	1
22	1000844-08	WASHER, 1/2" ID X .06", NYLON	1
23	PADLOCK	PADLOCK, BY OTHERS, REFERENCE	1
24	1000740	DATA PLATE	1

NOTES:
 PN: VSH-200-A-48-48-STN-GS
 DESC: WATER RESERVOIR SECURITY HATCH, ST, NO SKIRT, SERIES 48 X 48
 MATRL: 6061-T6 ALUMINUM
 EST. WT: 186.9
 FINISH: BARE
 NOTE: -
 CAD FILE: VSH-200-A-48-48-STN-GS-APPROVAL

TOLERANCES:

DIMENSIONS ARE IN INCHES
 TOLERANCES:
 X.XX ± 0.020"
 X.XXX ± 0.005"
 UNLESS NOTED

THIS DOCUMENT CONTAINS PROPRIETARY, TRADE SECRET, INFORMATION THAT IS THE PROPERTY OF VERSA STEEL, INC. THE INFORMATION CONTAINED IN THIS DOCUMENT, INCLUDING THE PRINCIPLE OF DESIGN, MAY NOT BE USED OR COPIED, IN WHOLE OR IN PART, WITHOUT THE EXPRESS PRIOR WRITTEN CONSENT OF VERSA STEEL, INC.

MATERIAL		6061-T6 ALUMINUM	
FINISH		BARE	
SHEET TITLE		WATER RESERVOIR SECURITY HATCH, ST, NO SKIRT, SERIES 48 X 48	
PART NUMBER		VSH-200-A-48-48-STN-GS	
SUPPLIER		FABRICATED PART	
SCALE		1:16	
DRAWING NO.		VSH-200-A-48-48-STN-GS-AP	
REVISION NO.		C	
SHEET NO.		3 OF 4	
REV	ISSUED FOR	DATE	BY
G			
F			
E			
D			
C			
B			
A			

VERSA STEEL, INC.
 1618 NE FIRST AVENUE
 PORTLAND, OREGON 97232
 (503)287-9822
 FAX (503)-287-7483

DRAWN BY
 E. BAILIFF
 DATE
 2020-11-25
 CHECKED BY

APPROVED BY

PART NUMBER: VSH-200-A-48-48-STN-GS

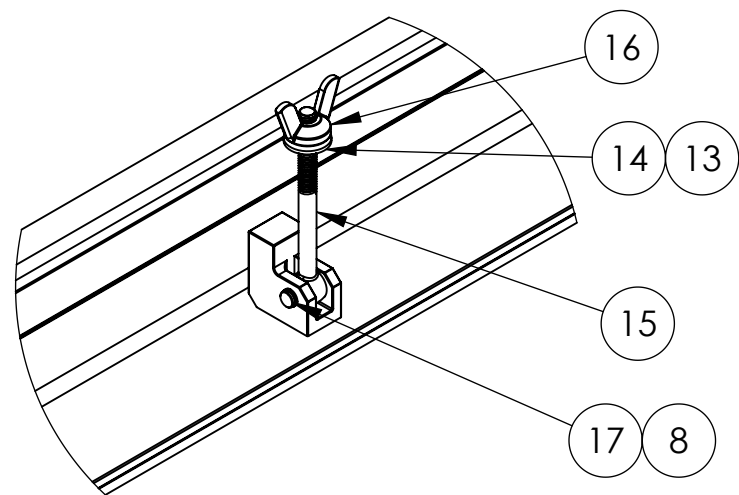
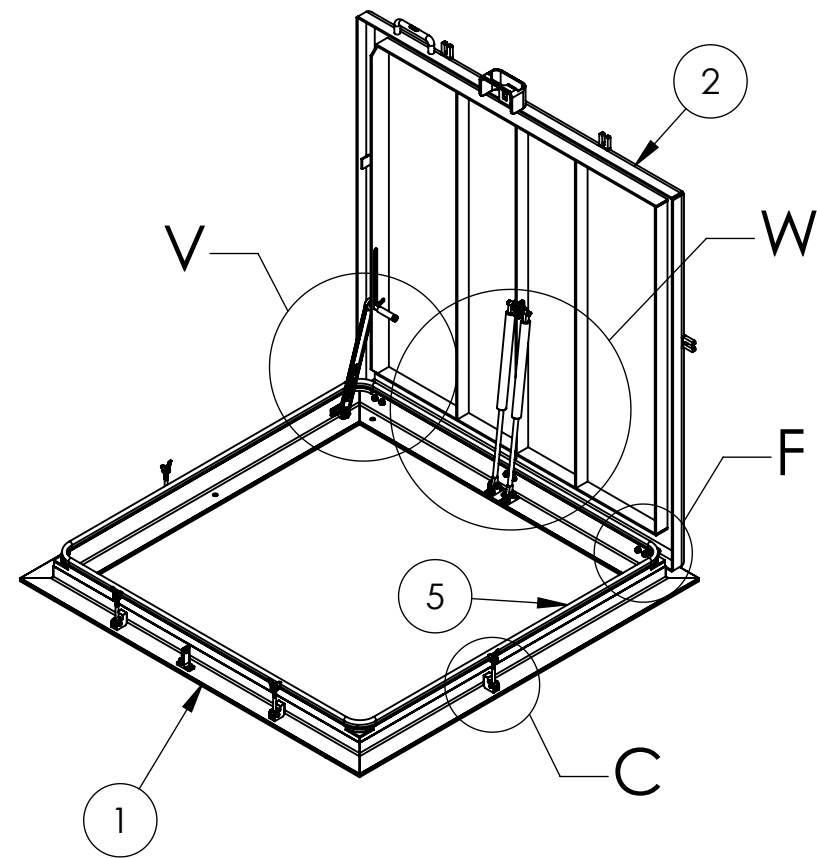

DETAIL C
SCALE 1 : 4

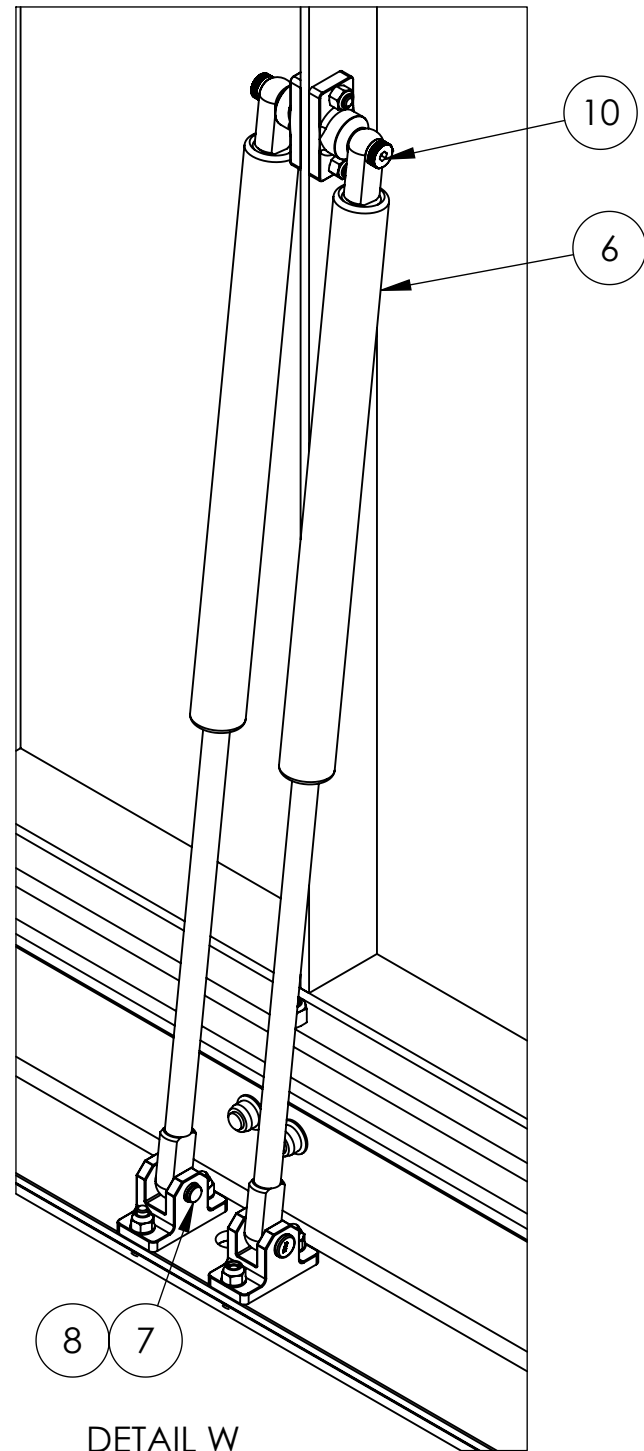

DETAIL W
SCALE 1 : 4

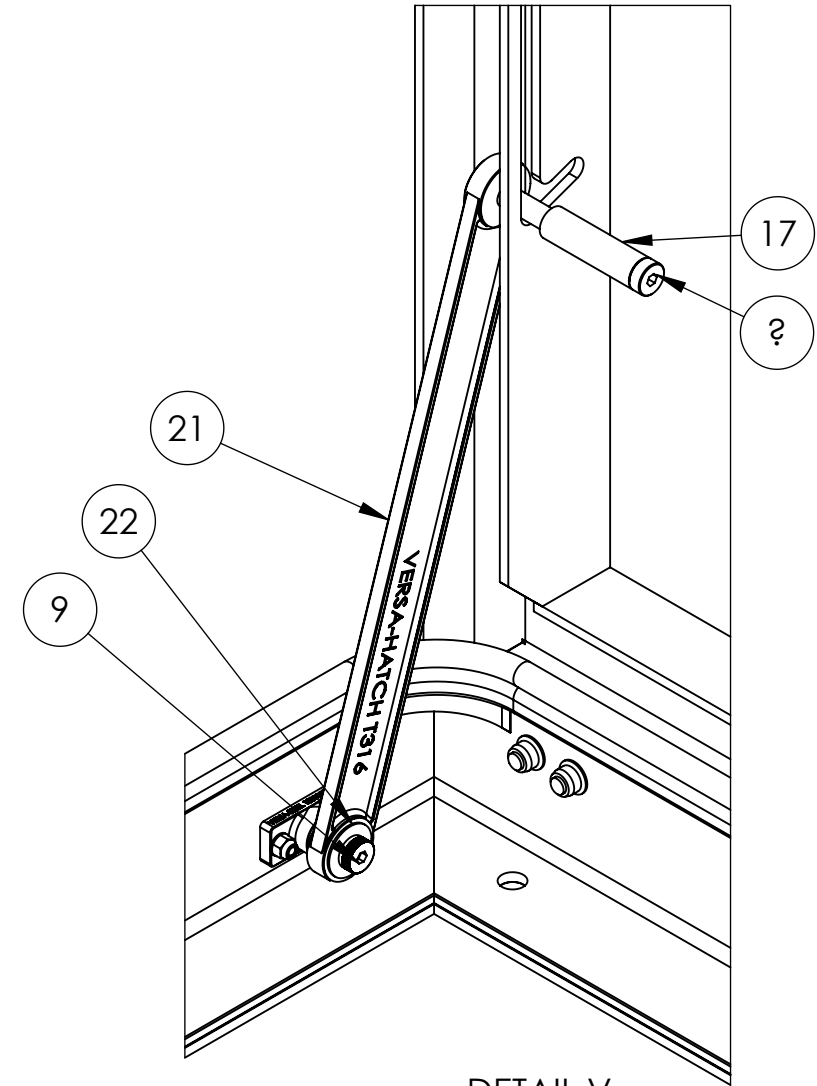

DETAIL V
SCALE 1 : 4

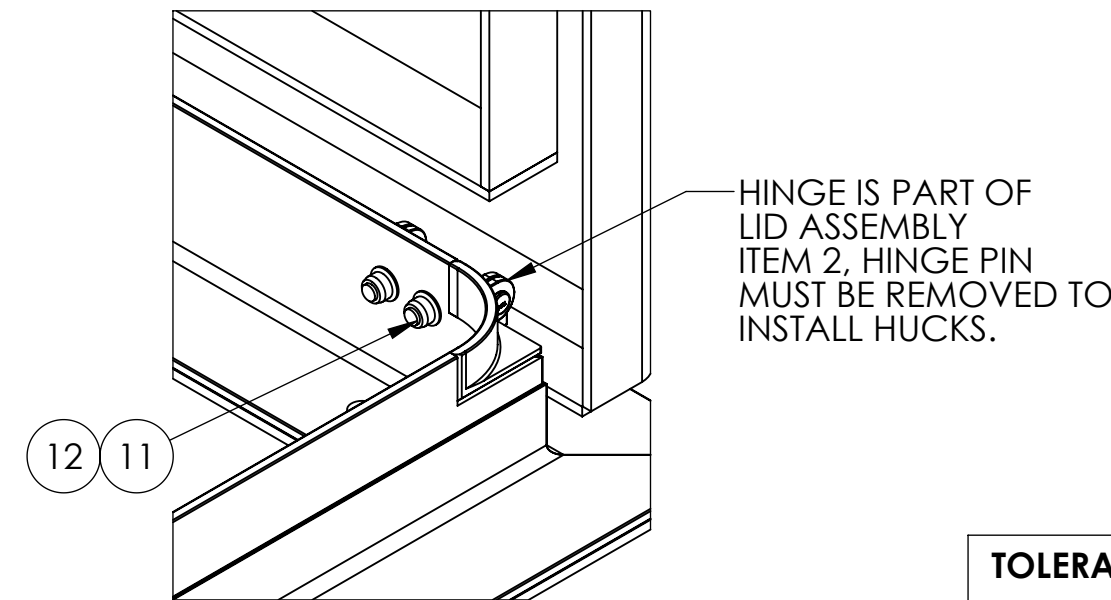

DETAIL F
SCALE 1 : 4

TOLERANCES:
DIMENSIONS ARE IN INCHES
TOLERANCES:
X.XX ± 0.020"
X.XXX ± 0.005"
UNLESS NOTED

THIS DOCUMENT CONTAINS PROPRIETARY, TRADE SECRET, INFORMATION THAT IS THE PROPERTY OF VERSA STEEL, INC. THE INFORMATION CONTAINED IN THIS DOCUMENT, INCLUDING THE PRINCIPLE OF DESIGN, MAY NOT BE USED OR COPIED, IN WHOLE OR IN PART, WITHOUT THE EXPRESS PRIOR WRITTEN CONSENT OF VERSA STEEL, INC.

MATERIAL	6061-T6 ALUMINUM			
FINISH	BARE			
SHEET TITLE	WATER RESERVOIR SECURITY HATCH, ST, NO SKIRT, SERIES 48XX (503)-287-7483			
PART NUMBER	VSH-200-A-48-48-STN-GS			
SUPPLIER	FABRICATED PART			
SCALE	1:24			
DRAWING NO.	VSH-200-A-48-48-STN-GS-AP			
REVISION NO.	C			
SHEET NO.	4 OF 4			
REV	A	ISSUED FOR	DATE	BY
G				
F				
E				
D				
C				
B				
A				

VERSA STEEL, INC.
1618 NE FIRST AVENUE
PORTLAND, OREGON 97232
(503)287-9822
FAX (503)-287-7483

DRAWN BY
E. BAILIFF
DATE
2020-11-25
CHECKED BY

APPROVED BY

PART NUMBER: VSH-200-A-48-48-STN-GS