

# VERSA STEEL Approval Drawings

## HATCH ASSEMBLY-GAS SPRING, 36 X 36

Assembly No.: VSH-150-A-36-36-S-GS

### ASSEMBLY NO./PART NUMBER KEY:

VSH= VERSA STEEL INC. HATCH  
 150 = 150 P.S.F. RATED  
 A= ALUMINUM CONSTRUCTION  
 36-36= SIZE INTERIOR OPENING  
 S = SINGLE LEAF  
 GS= GAS SPRING ASSIST

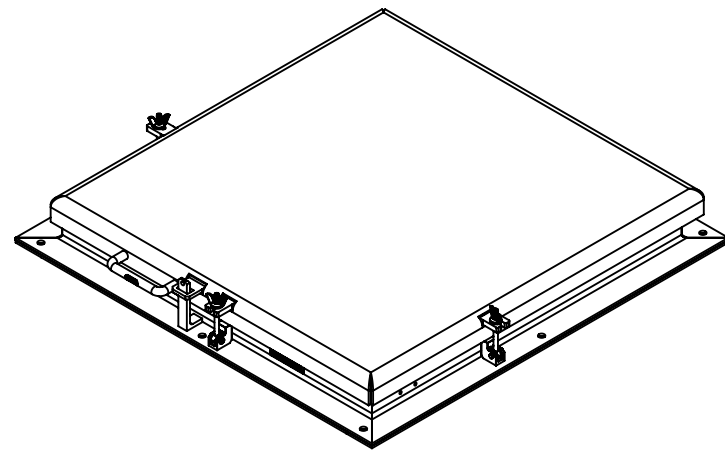

### GENERAL SPECIFICATIONS:

1. UNIT IS WEATHER PROOF WITH CONTINUOUS BULB SEAL ON LID TO FRAME AND 1/4" X 3" WIDE FRAME TO CURB SEALS.
2. LID OVER LAPS FRAME A MINIMUM OF 2 INCHES.
3. FRAME IS A MINIMUM OF 4" ABOVE THE CURB.
4. LID IS HINGED ON SIDE WITH TAMPER PROOF SCREWS . THERE ARE A MINIMUM OF THREE SWING BOLT HOLD DOWNS TO SECURE THE HATCH FOR WEATHER PROOF SEAL.
5. HATCH IS DESIGNED FOR 150 P.S.F. LOAD.
6. THERE ARE 8 EXTERIOR ATTACHMENT POINTS FOR 1/2" FASTENER. THERE IS A FULL FACE GASKET OF 3" WIDE CLOSED CELL FOAM EPDM BETWEEN FRAME AND CURB.
7. LID IS A 1/4" 5086 FORMED ALUMINUM PLATE.
8. ALL FASTENERS AND HARDWARE ARE 316 STAINLESS STEEL.

THIS DOCUMENT CONTAINS PROPRIETARY, TRADE SECRET, INFORMATION THAT IS THE PROPERTY OF VERSA STEEL, INC. THE INFORMATION CONTAINED IN THIS DOCUMENT, INCLUDING THE PRINCIPLE OF DESIGN, MAY NOT BE USED OR COPIED, IN WHOLE OR IN PART, WITHOUT THE EXPRESS PRIOR WRITTEN CONSENT OF VERSA STEEL, INC.

VERSA STEEL, INC. 1618 NE FIRST AVENUE PORTLAND, OREGON 97232 (503)287-9822 FAX (503)-287-7483	DRAWN BY E. BAILIFF DATE 2013-12-23 CHECKED BY	APPROVED BY	REV. ISSUED FOR BY G F E D C B A
MATERIAL 6061-T6 ALUMINUM FINISH BARE SHEET TITLE HATCH ASSEMBLY-GAS SPRING, 36 X 36 PART NUMBER: VSH-150-A-36-36-S-GS	PART NUMBER VSH-150-A-36-36-S-GS SUPPLIER FABRICATED PART SCALE 1:16 DRAWING NO. VSH-150-A-36-36-S-GS-APPF REVISION NO. D		
SHEET NO. 1 OF 3			

NOTE:  
LOCTITE ALL SHOULDER BOLTS.

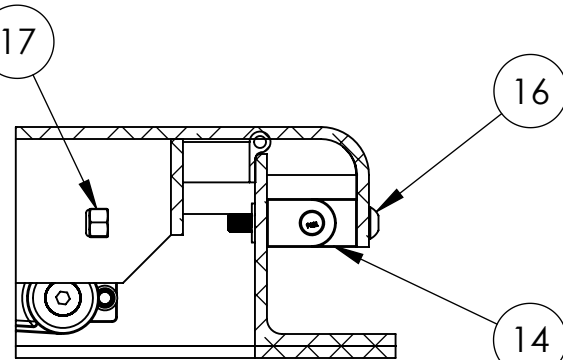
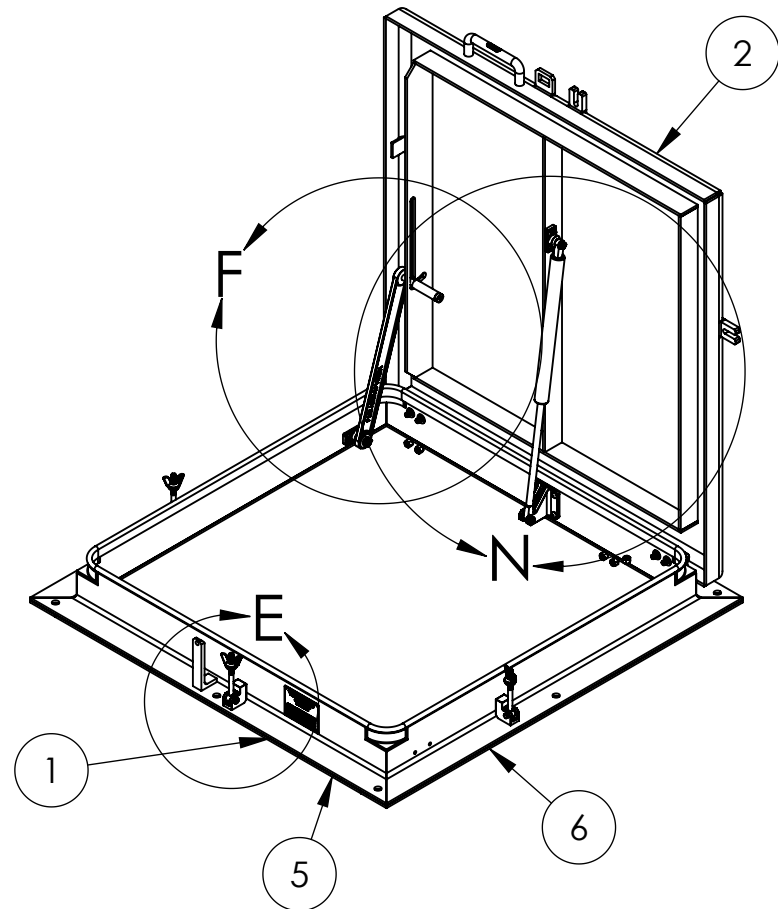

SECTION M-M  
SCALE 1 : 4

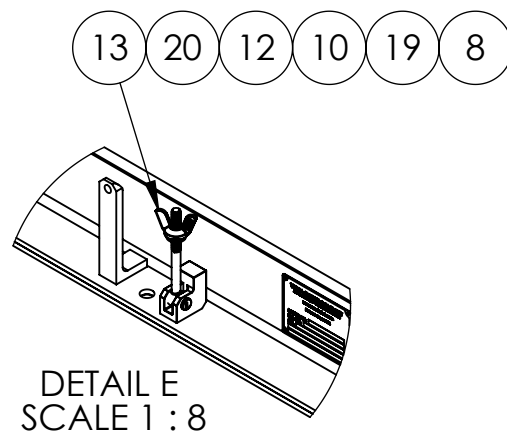

DETAIL E  
SCALE 1 : 8

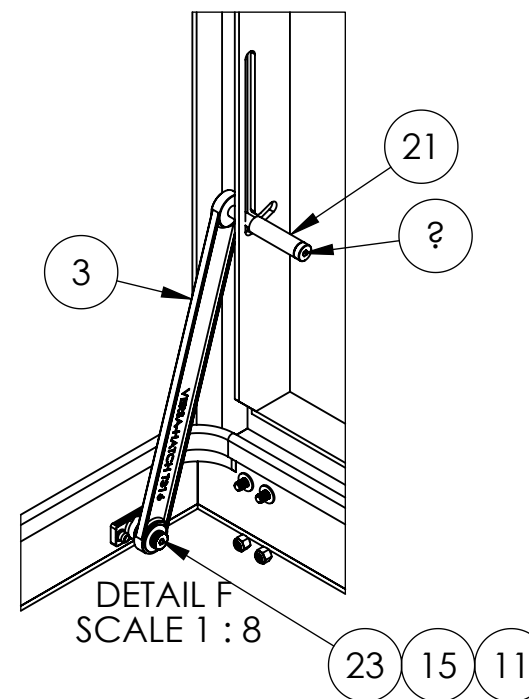

DETAIL F  
SCALE 1 : 8

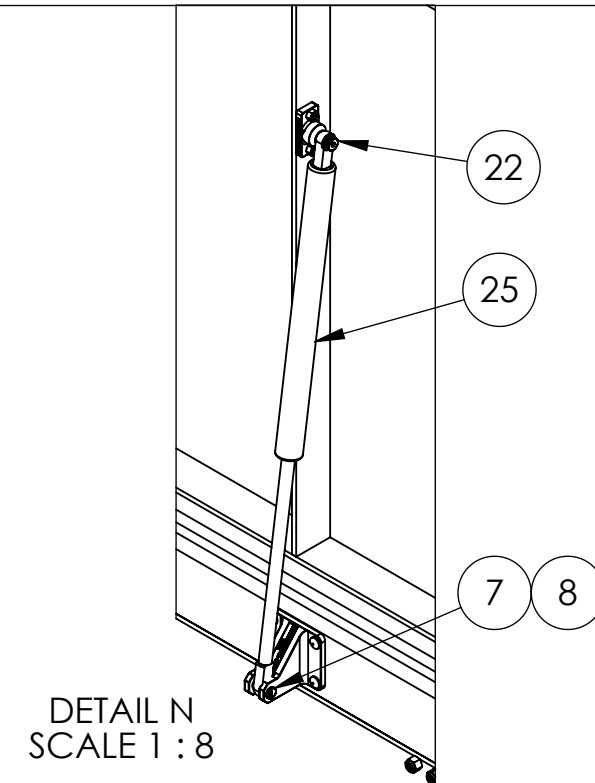

DETAIL N  
SCALE 1 : 8

ITEM NO.	PART NUMBER	DESCRIPTION	QTY
1	7000544-36X36	FRAME 36 X 36	1
2	7000545-36X36	LID WELDMENT 36 X 36	1
3	1000524-24	3/4" HOLD OPEN ARM, 24, 316 SST	1
4	1000525-36X36	HATCH SEAL, 36 X 36	1
5	1000527-36	SEAL, BASE WIDTH 36	2
6	1000526-36	SEAL, BASE SIDE 36	2
7	1000756	Clevis Pin 3/8x1-1/4	1
8	VS-37	.375 Dia External, single turn, retaining ring-T316	4
9	1000740	DATA PLATE	1
10	1000664	Clevis Pin 3/8x1	3
11	GFI-0809-08	FLANGED BEARING	1
12	1000059	ROD END 3/8" ID X 3/4" OD X 4 1/2" LG W/ 3/8-16 THRD X 2" LG	3
13	1000061	WING NUT, 3/8-16 UNC	3
14	7000543	PINTLE HINGE ASSEMBY-T316	2
15	1000844-08	WASHER, 1/2" ID X .06", NYLON	1
16	1001739-16	Pin-Allen Button Head, -3/8-16 X 1, 18-8	8
17	1000796-06	HEX NUT, NYLON LOCKING, 3/8-16, 316	8
18	1000060	SH SHOULDER SCREW, 3/8"-16 X 1/2" X 4.0 LG 316	1
19	1000793-06	SRING LOCK WASHER, 3/8", 316	3
20	1000791-06	WASHER, FLAT, NARROW, 3/8", 316	11
21	9446K71	LOCK BAR COVERING, GP PVC TUBING, RED	1
22	1000657	Shoulder Bolt 3/8x 1/2	1
23	1000656	Shoulder Bolt 1/2x5/8	1
24	90295A170	FLAT WASHER 3/8" NYLON	1
25	1165-10-100-FO-C2C2	STAINLESS STEEL GAS SPRINGS, 10" STROKE, 100 LBS	1

NOTES:  
PN: VSH-150-A-36-36-S-GS  
DESC: HATCH ASSEMBLY-GAS SPRING, 36 X 36  
MATRL: 6061-T6 ALUMINUM  
EST. WT: 91.5  
FINISH: BARE  
NOTE: -  
CAD FILE: VSH-150-A-36-36-S-GS-APPROVAL

THIS DOCUMENT CONTAINS PROPRIETARY, TRADE SECRET, INFORMATION THAT IS THE PROPERTY OF VERSA STEEL, INC. THE INFORMATION CONTAINED IN THIS DOCUMENT, INCLUDING THE PRINCIPLE OF DESIGN, MAY NOT BE USED OR COPIED, IN WHOLE OR IN PART, WITHOUT THE EXPRESS PRIOR WRITTEN CONSENT OF VERSA STEEL, INC.

VERSAS STEEL, INC.  
1618 NE FIRST AVENUE  
PORTLAND, OREGON 97232  
(503)287-9822  
FAX (503)-287-7483

DRAWN BY  
E. BAILIFF  
DATE  
2013-12-23  
CHECKED BY

APPROVED BY

MATERIAL  
6061-T6 ALUMINUM  
FINISH  
BARE  
SHEET TITLE  
HATCH ASSEMBLY-GAS SPRING, 36 X 36  
PART NUMBER: VSH-150-A-36-36-S-GS

PART NUMBER  
VSH-150-A-36-36-S-GS  
SUPPLIER  
FABRICATED PART  
SCALE  
1:16  
DRAWING NO.  
VSH-150-A-36-36-S-GS-APPR  
REVISION NO.  
D  
SHEET NO.  
2 OF 3

REV	A	B	C	D	E	F	G
ISSUED FOR							
DATE							
BY							

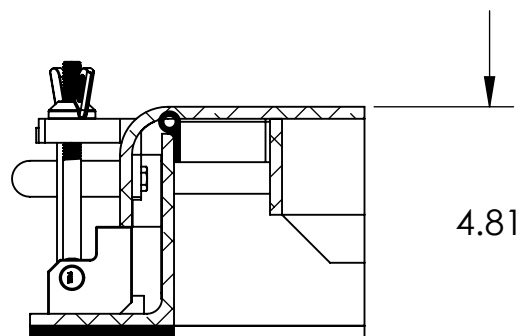
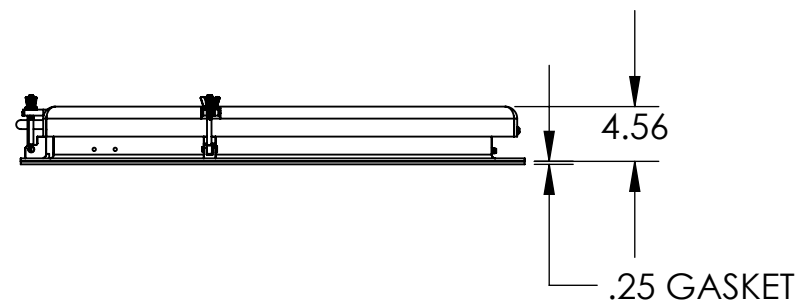
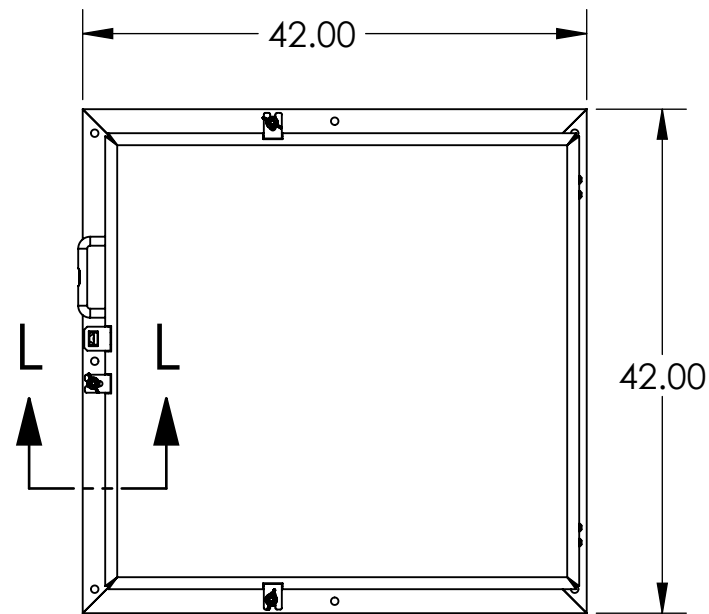

SECTION L-L  
SCALE 1 : 4

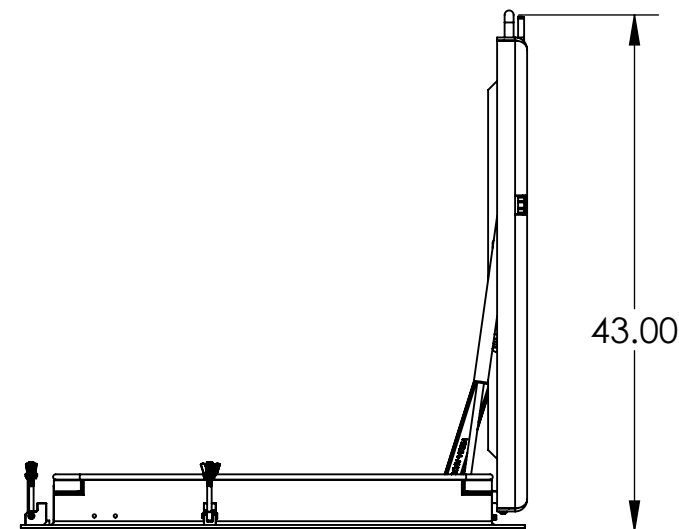
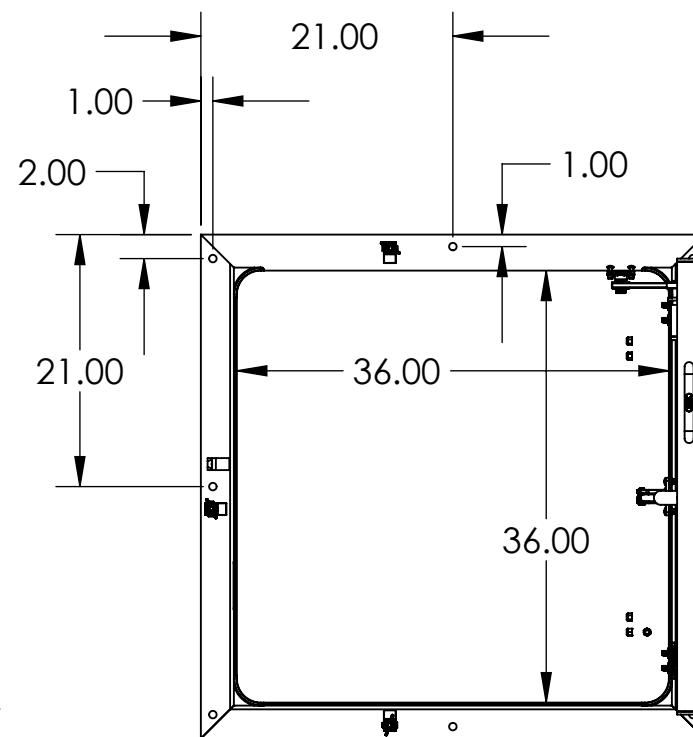

NOTES:  
 PN: VSH-150-A-36-36-S-GS  
 DESC: HATCH ASSEMBLY-GAS SPRING, 36 X 36  
 MATRL: 6061-T6 ALUMINUM  
 EST. WT: 91.5  
 FINISH: BARE  
 NOTE: -  
 CAD FILE: VSH-150-A-36-36-S-GS-APPROVAL

THIS DOCUMENT CONTAINS PROPRIETARY, TRADE SECRET INFORMATION THAT IS THE PROPERTY OF VERSA STEEL, INC. THE INFORMATION CONTAINED IN THIS DOCUMENT, INCLUDING THE PRINCIPLE OF DESIGN, MAY NOT BE USED OR COPIED, IN WHOLE OR IN PART, WITHOUT THE EXPRESS PRIOR WRITTEN CONSENT OF VERSA STEEL, INC.

VERSA STEEL, INC.  
 1618 NE FIRST AVENUE  
 PORTLAND, OREGON 97232  
 (503)287-9822  
 FAX (503)-287-7483

DRAWN BY  
 E. BAILIFF  
 DATE  
 2013-12-23  
 CHECKED BY

APPROVED BY

MATERIAL  
 6061-T6 ALUMINUM  
 FINISH  
 BARE  
 SHEET TITLE  
 HATCH ASSEMBLY-GAS SPRING, 36 X 36  
 PART NUMBER: VSH-150-A-36-36-S-GS

PART NUMBER  
 VSH-150-A-36-36-S-GS  
 SUPPLIER  
 FABRICATED PART  
 SCALE  
 1:16  
 DRAWING NO.  
 VSH-150-A-36-36-S-GS-APPR  
 REVISION NO.  
 D

SHEET NO.  
 3 OF 3

REV	ISSUED FOR	DATE	BY
G			
F			
E			
D			
C			
B			
A			