

Tank Indicator Installation

Model: VS-E020, Stainless Reverse Read System

Guide Cables

No Guide Cables

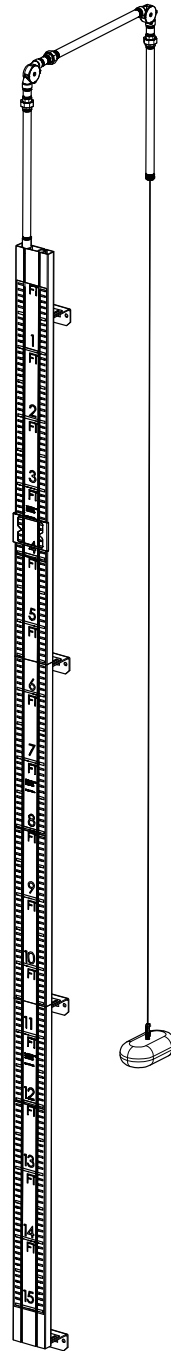
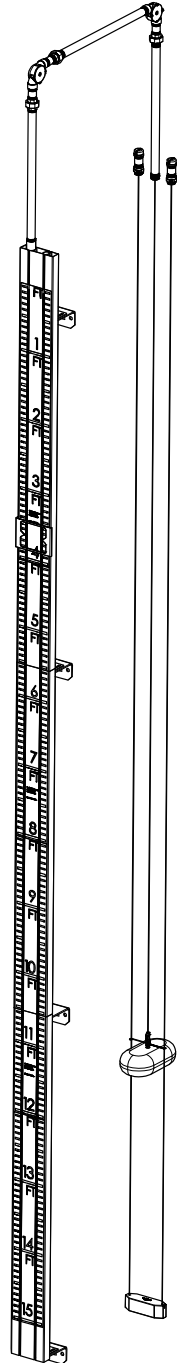

TANK BRACKET POSITIONING

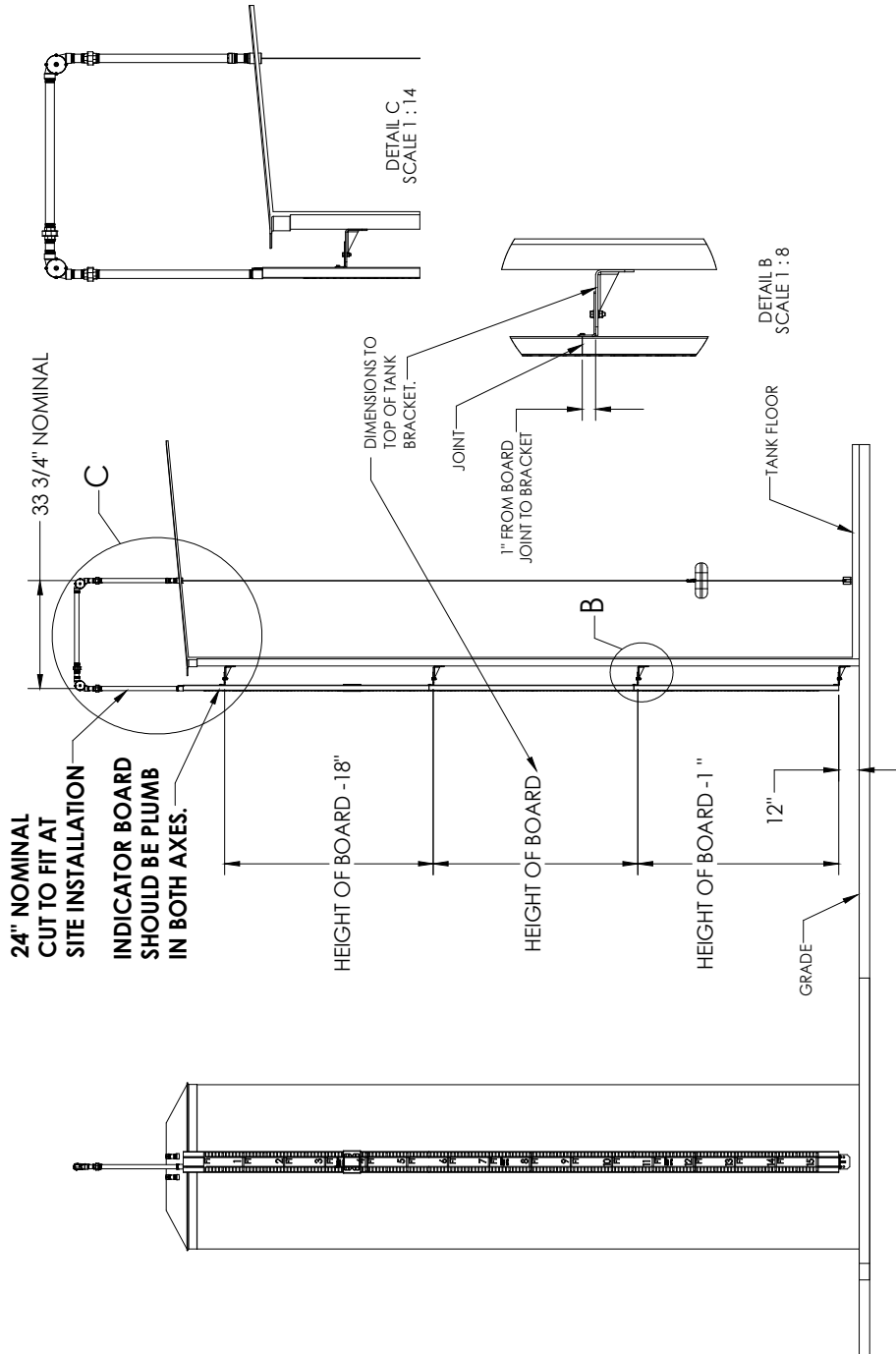

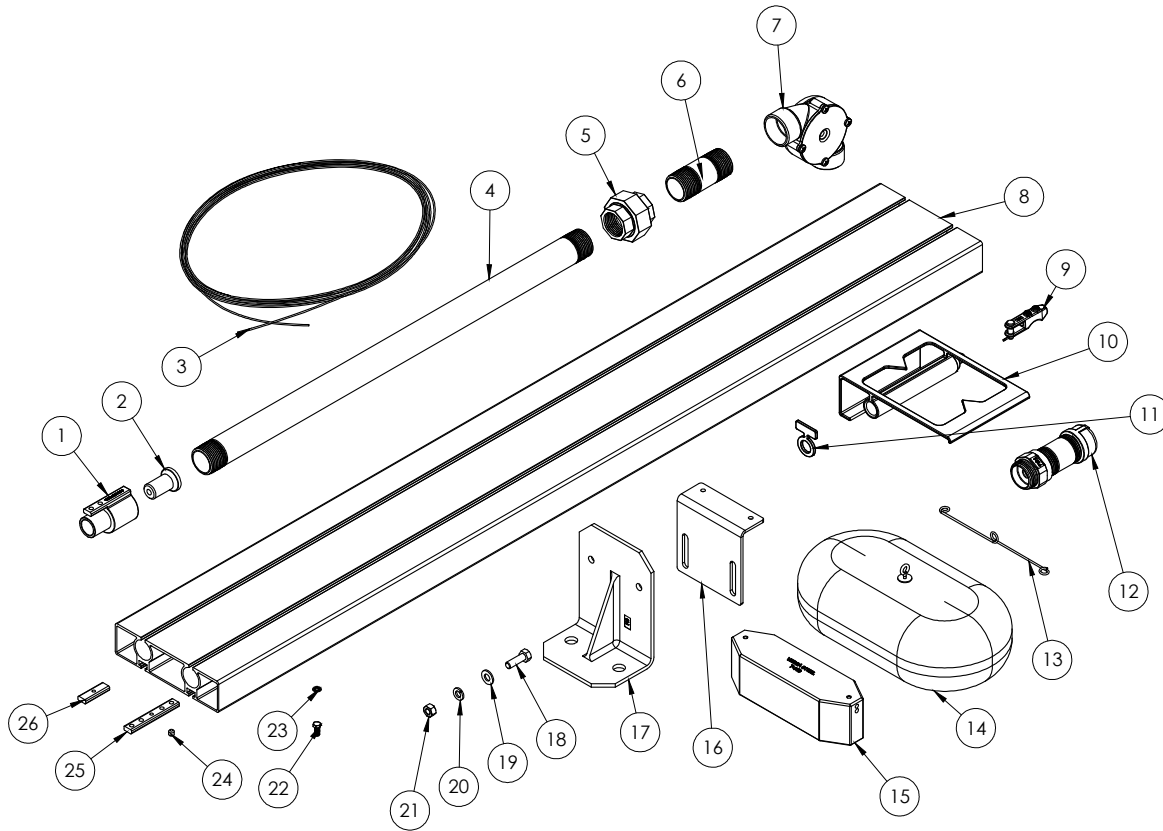

ITEM #	PART #	DESCRIPTION
1	1001203	ADAPTER, STAFF GAUGE BOARD TO 1" NPT
*** 2	1001426	SLEEVE INSERT
3		CABLE, 1/16" 7x7, T-316
4	1000067	PIPE NIPPLE, 1" NPT X 24"
5	1000006	UNION, 1" NPT
6	1000010	PIPE NIPPLE, 1" NPT X 3"
7	7000630	SHEAVE HOUSING ASSEMBLY
8	1001201	STAFF GAUGE BOARD
9	7000006	CABLE CLAMP
10	7000713	TARGET, WINDOW STYLE
11	1001291	CAMMING TAB
12	7000478	GUIDE CABLE TENSION ASSEMBLY
13	1001211	GUIDE WIRE, 6-1/2"
14	7000711	STAINLESS FLOAT
15	1001216	WEIGHTED BLOCK
16	1001241	UNIVERSAL MOUNTING BRACKET
17	1000068	TANK BRACKET
18		BOLT, HEX, 5/16"-24 X 1", T-316
19		WASHER, FLAT, NARROW, 5/16", T-316
20		WASHER, SPLIT LOCK, 5/16", T-316
21		NUT, HEX, 5/16"-18, T-316
22		SCREW, HEX, #10-32 X 1/2", T-316
23		WASHER, INTERNAL TOOTH LOCK, #10, T-316
24		SET SCREW, CUP POINT, 1/4"-20 X 1/4", T-316
25	1001207	NUT, T-SLOT, LONG
26	1001204	NUT, T-SLOT, SHORT

Part quantities vary based on project requirements.

***** Parts are optional.**

INSTALLATION REQUIREMENTS

- *The customer is assumed to use all **safety precautions, devices, and procedures**, especially when working in elevated locations.*
- *Edges and threads may be sharp. Always wear **gloves** when handling parts.*
- A **plumb-bob** or similar device is recommended.
- Customer provides **sealant for pipe joints**
- Customer drills holes in the tank roof where **customer-provided 1” NPT Couplings** are to be installed. (Quantity 3 pcs. when guide cables are used; 1 pc. without guide cables.) The holes should be placed as close as possible to an access hatch.
- Depending on field conditions, customer may need to **adjust the length** of the provided 1” NPT Pipe Nipples, and **re-thread** them.
- Customer **welds and/or fastens the Tank Brackets to the tank wall**. If unable to mount directly to the tank wall, brackets can be mounted to a customer-supplied support.
- Customer is recommended, if possible, to **weld and/or fasten** the Weighted Block to the tank floor.
- It might be necessary to use a **Phillips head screwdriver** and **needle-nose pliers** to disassemble the Sheave Housing assembly.

STEP A - Deciding How to Mount Staff Gauge Boards



WARNING: DO NOT JOIN UNMOUNTED STAFF GAUGE BOARDS. LONG T-SLOT NUTS WILL NOT RESIST BENDING, AS PICTURED. STAFF GAUGE BOARDS MUST BE MOUNTED ONE-AT-A-TIME.



- **Option A (Mounting to Tank):**

If field conditions permit, prepare to mount the Tank Brackets directly to the tank wall. You will alternate between mounting Tank Brackets and attaching Staff Gauge Boards, working from the bottom up. This will be described in more detail later on in the instruction manual.

- **Option B (Mounting to Customer Supplied Channel):**

If unable to mount Tank Brackets directly to the tank, the Tank Brackets can be mounted instead to a support channel. This channel is supplied by the customer, and should be at least 5" wide and as tall as the tank. It should be sturdy enough in order to sufficiently support Staff Gauge Board assembly. Once all components of the Staff Gauge Board assembly have been mounted to the channel, the entire assembly can be raised to be parallel with the tank wall. It will be up to the customer to decide how to affix the channel to the tank wall. ***Make sure that the bottom Staff Gauge Board is at least 12" above the grade (refer to Diagram 1A).***

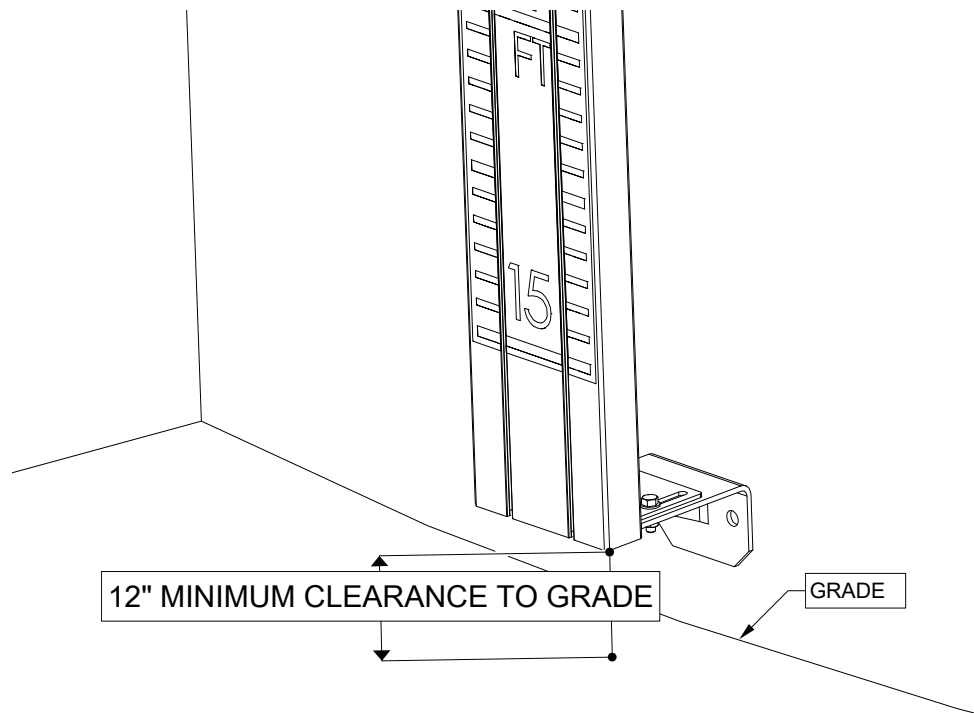
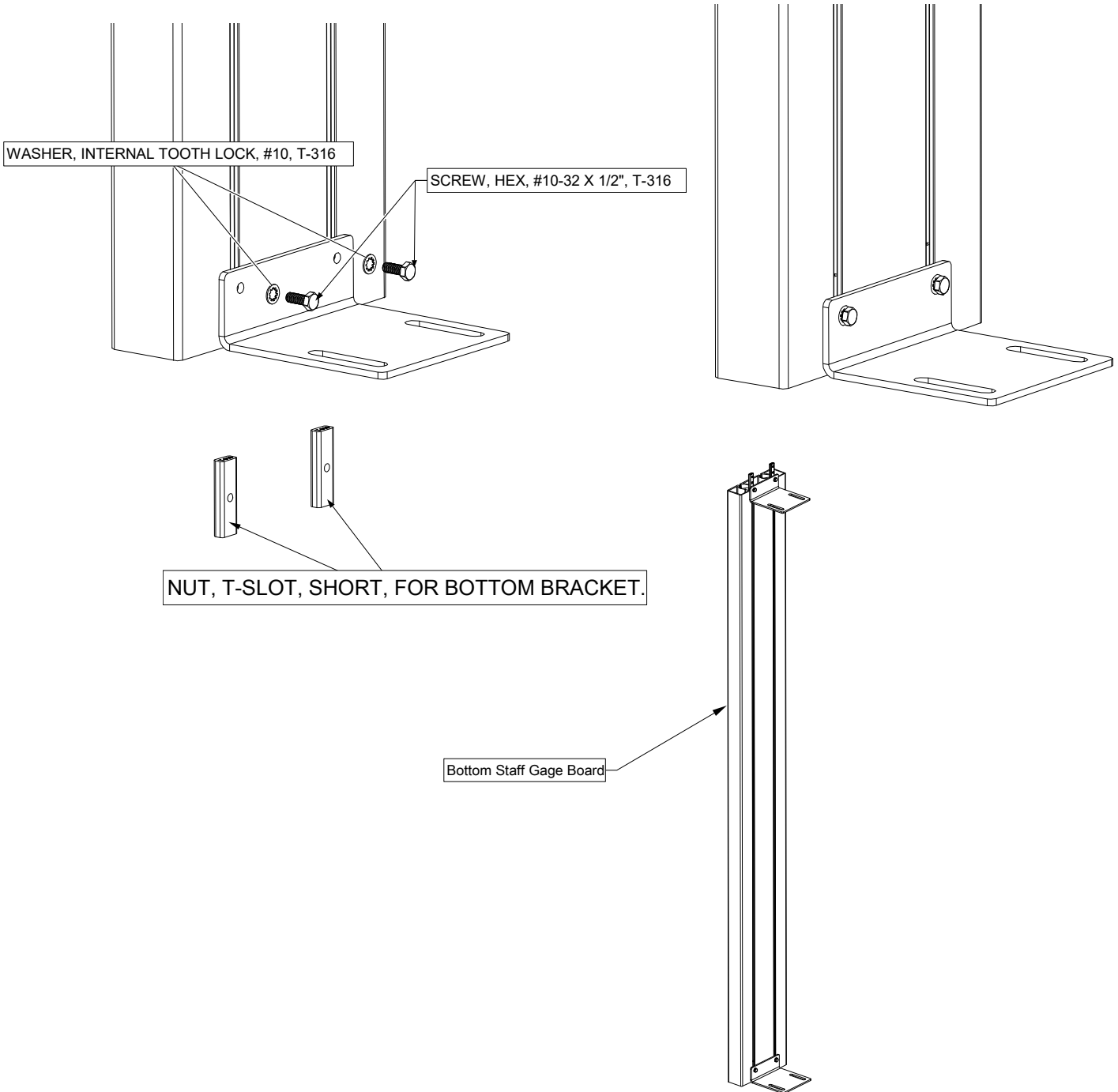

Diagram 1A

STEP B – Attach Universal Mounting Bracket to Staff Gauge Boards

1. Each Staff Gauge Board comes with a vinyl decal displaying height values. Arrange the boards on a flat surface in the correct order/orientation.
2. Assemble the bottom Staff Gauge Board as follows.



STEP B – Attach Universal Mounting Bracket to Staff Gauge Boards

3. Each Staff Gauge Board comes with a vinyl decal displaying height values. Arrange the boards on a flat surface in the correct order/orientation.
4. Assemble the bottom Staff Gauge Board as follows.

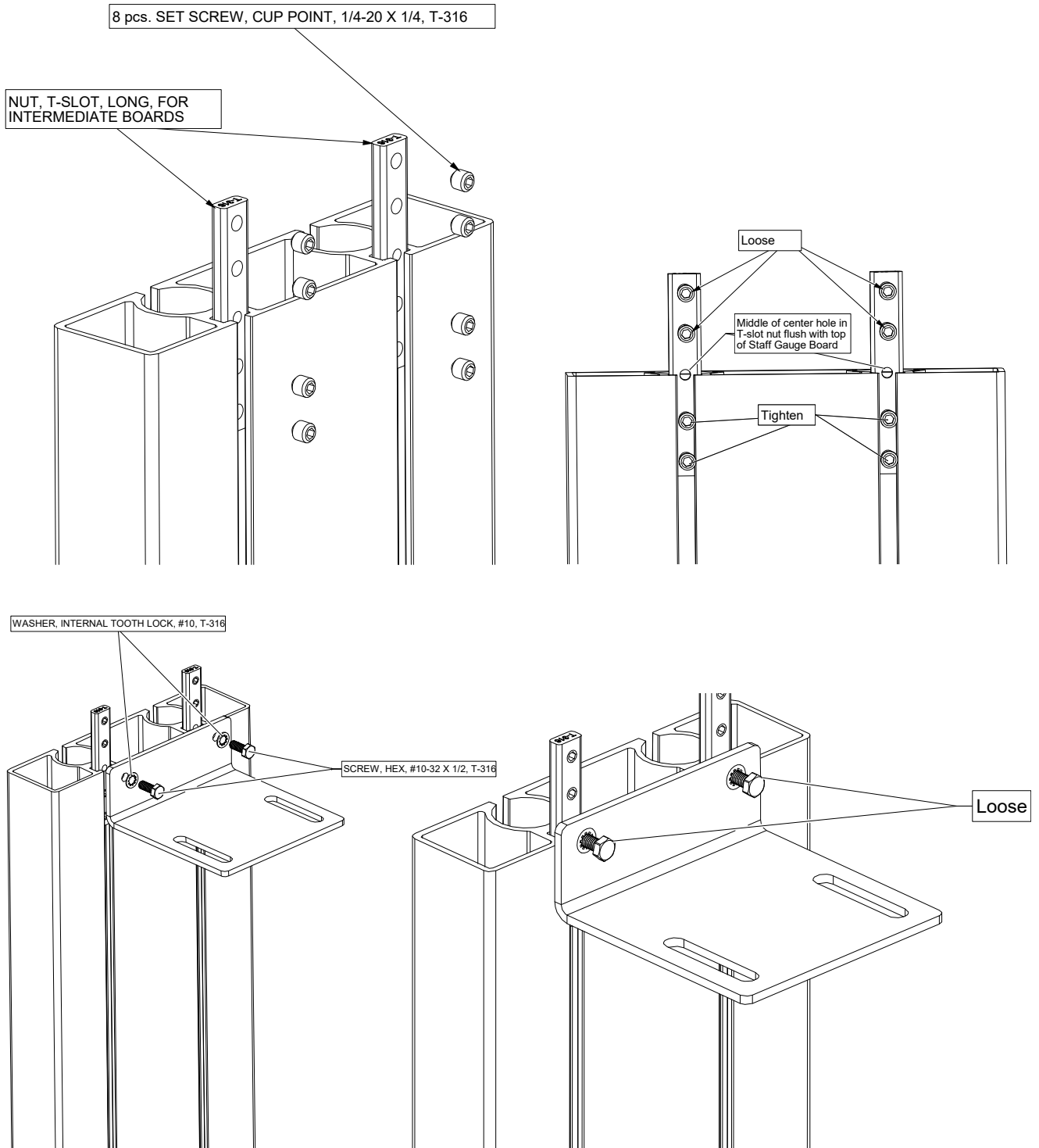

5. STEP B - Continued

5. Prepare the top Staff Gauge Board as follows.

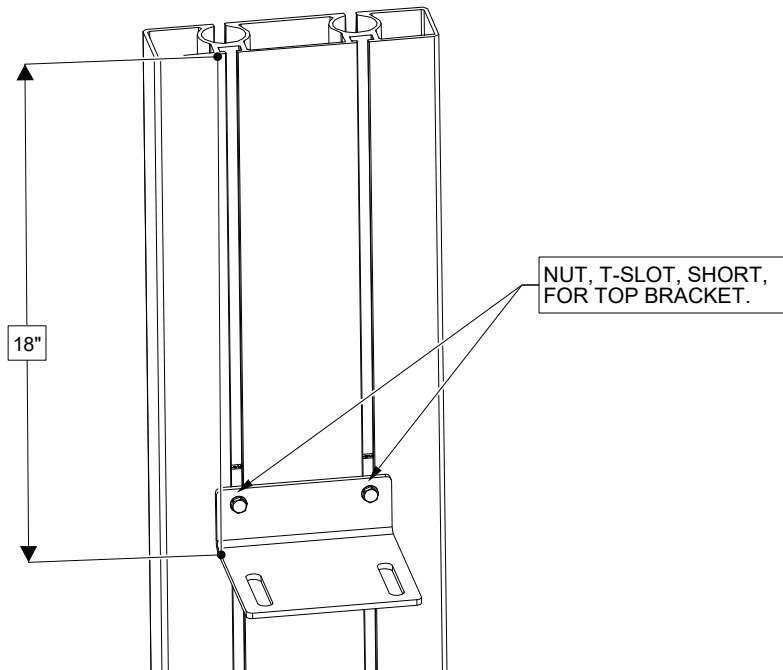
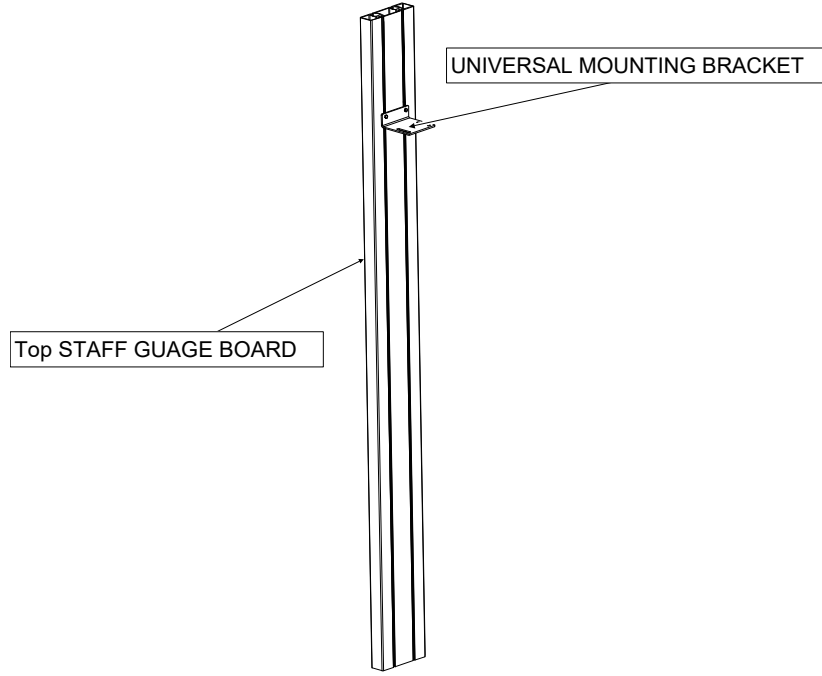

STEP C – 1: Attach Tank Brackets

2: Mount Staff Gauge Boards

1. **Tank Brackets will be attached to the tank wall in accordance with the diagram on Page 2. Begin by attaching the bottommost two Tank Brackets and then mounting the bottom Staff Gauge Board as follows. The height between the bottom two Tank Brackets is the height of the bottom Staff Gauge Board minus 1". Leave at least 12" clearance between the bottom of the tank bracket and grade (See Page 2). CHECK TANK BRACKETS FOR LEVEL AND PLUMB. CHECK BOTTOM STAFF GAUGE BOARD FOR PLUMB.**

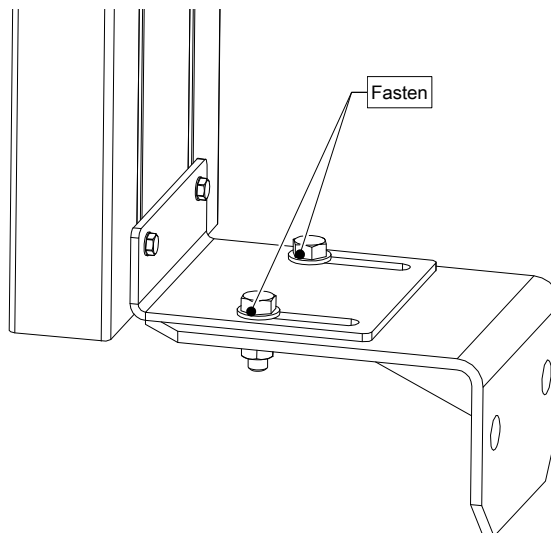
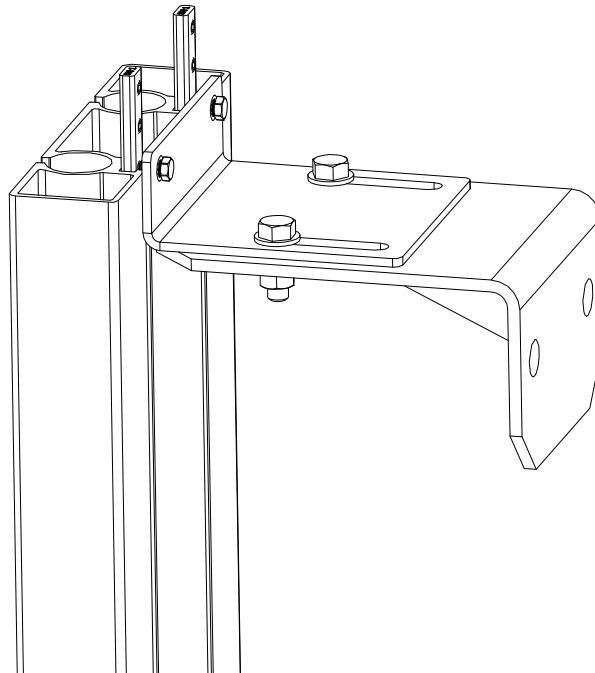

STEP C – Continued

2. For each intermediate Staff Gauge Board, attach the next Tank Bracket and mount the corresponding Staff Gauge Board as follows. The height between consecutive Tank Brackets is **equal to** the height of the corresponding Staff Gauge Board. **ALWAYS CHECK FOR LEVEL AND PLUMB.**

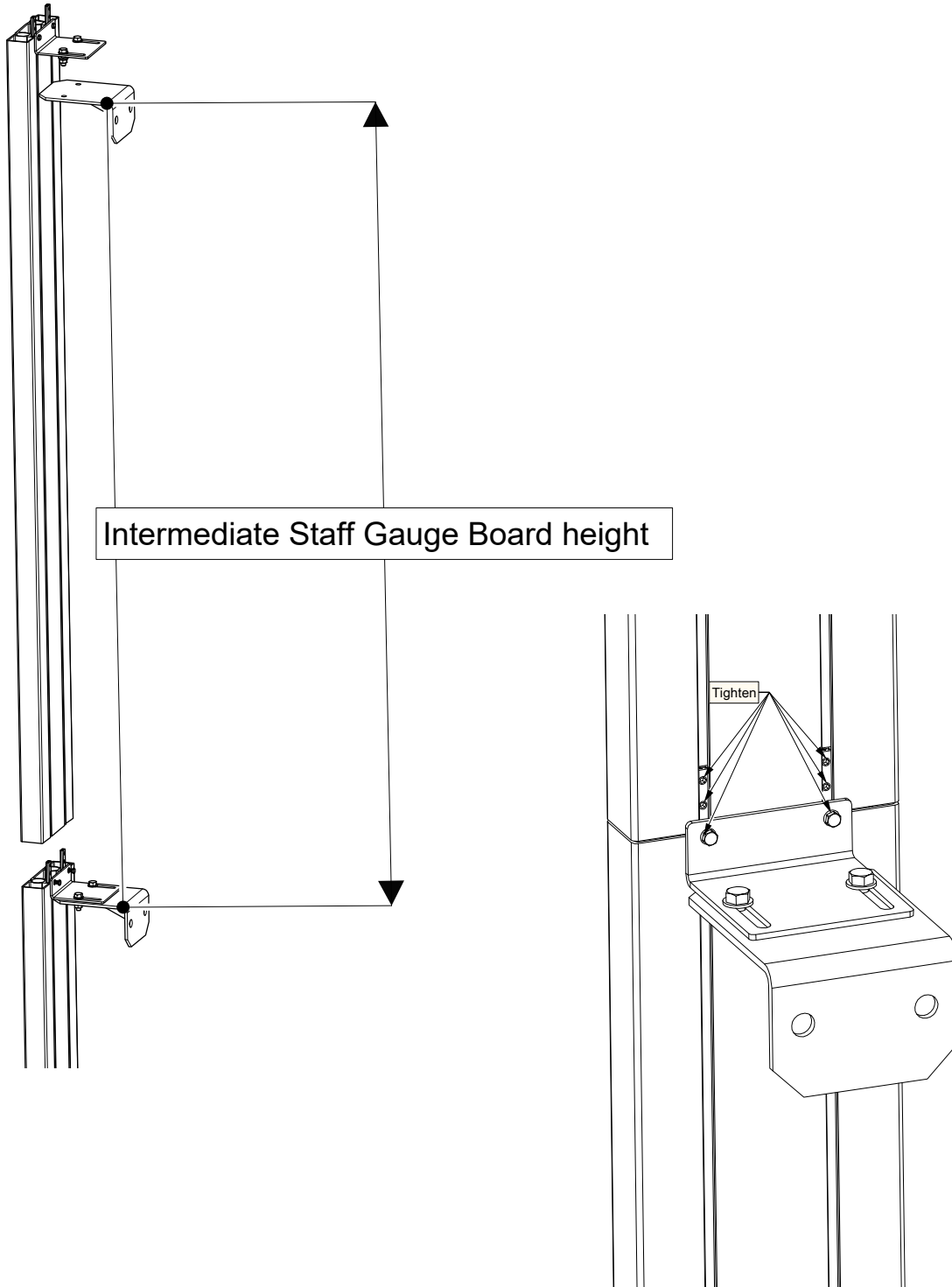

STEP C – Continued

3. Attach the top Tank Bracket and mount the top Staff Gauge Board as follows. The height between the two topmost Tank Brackets is the height of the top Staff Gauge Board **minus 18"**. The Staff Gauge Boards are now mounted. **ALWAYS CHECK FOR LEVEL AND PLUMB.**

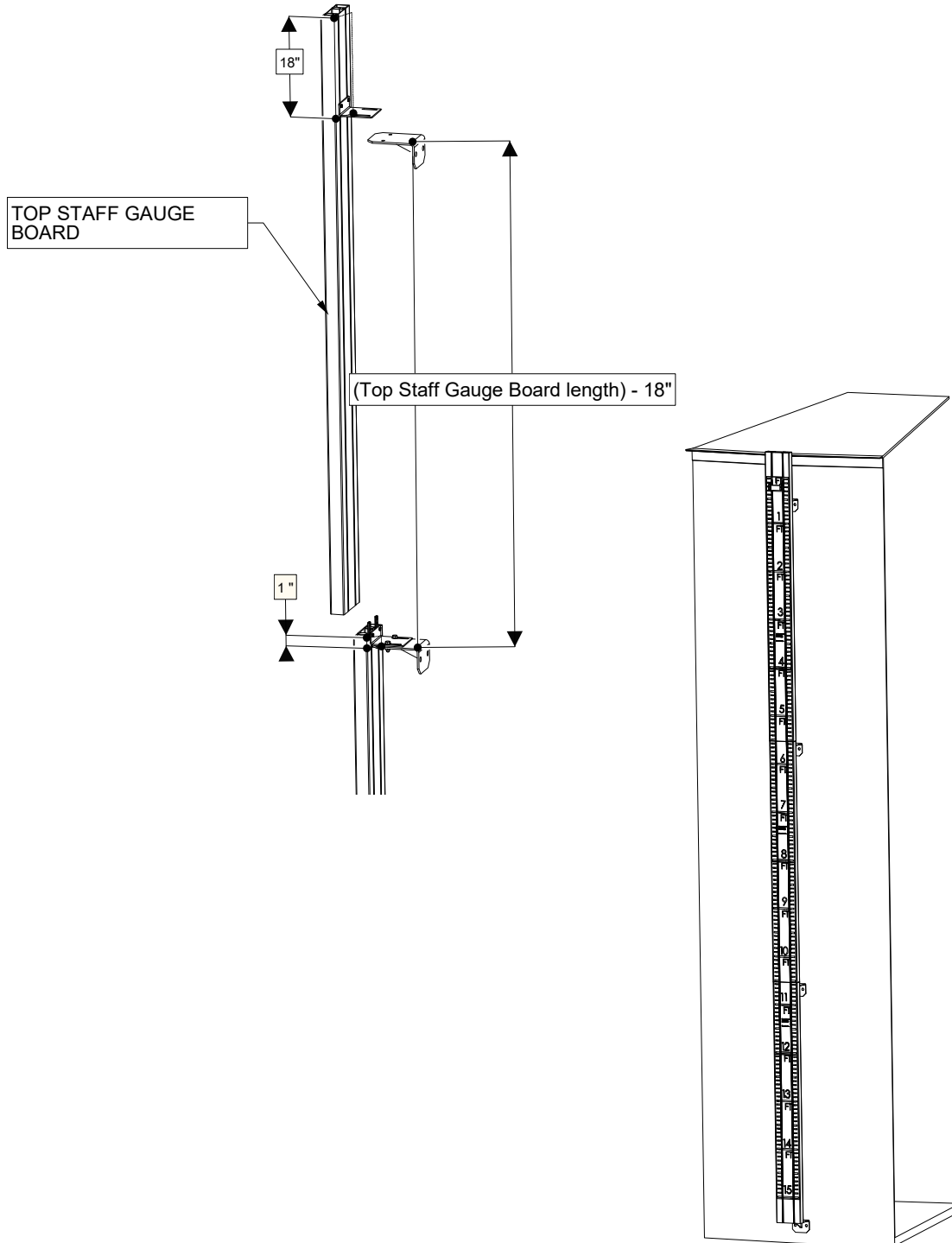

STEP D – Build Reeving Assembly

The Reeving Assembly consists of four pieces which connect via 1” Unions. Assemble each of the four parts using the following components. Don't seal pipe joints at this time.

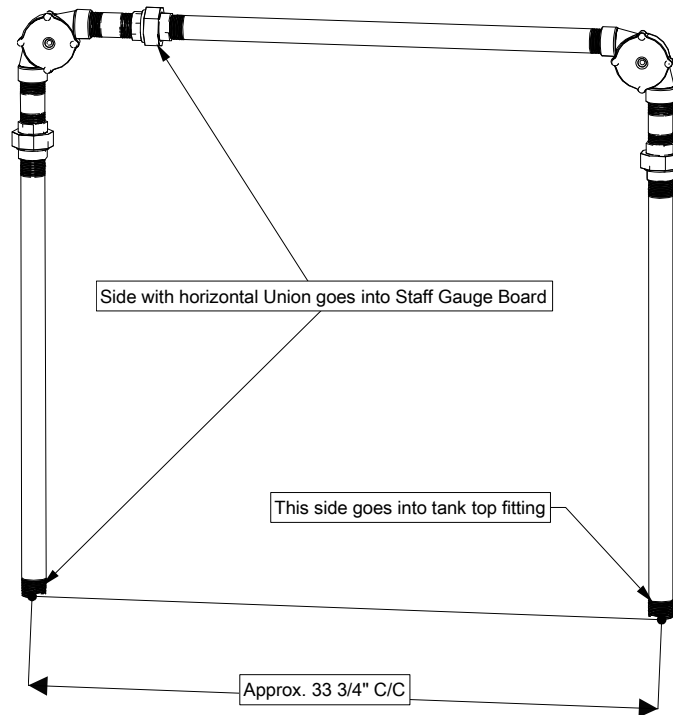
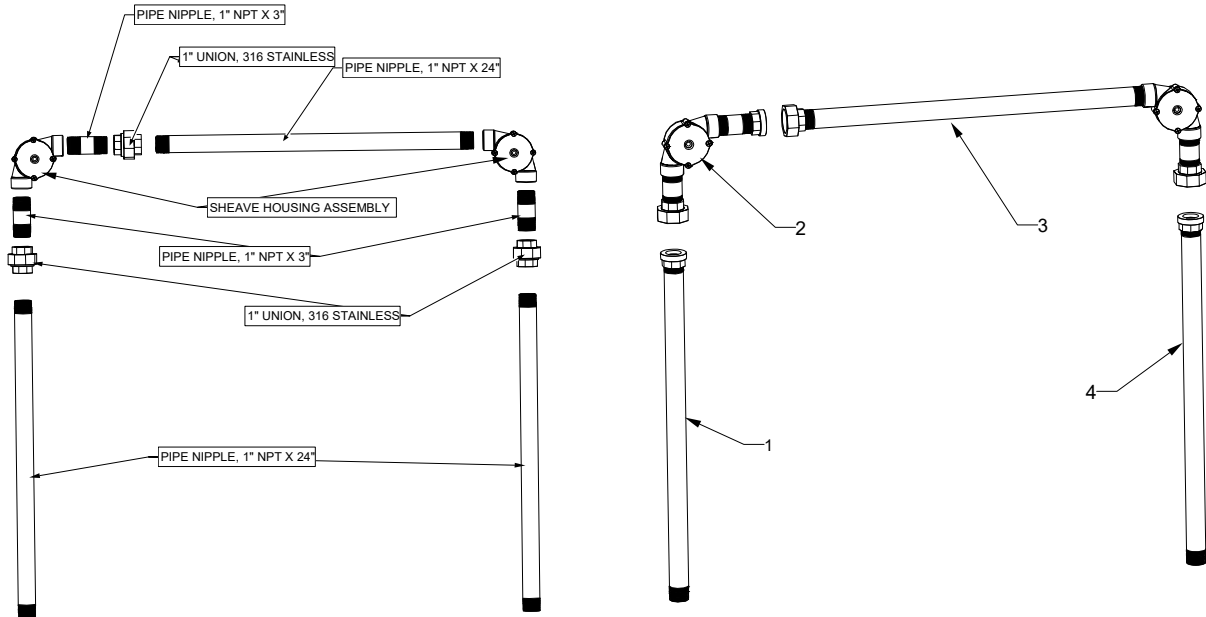

STEP F – Measure for Mounting Reeving Assembly to Tank Roof

1. Temporarily mount the Reeving Assembly to the top Staff Gauge Board.
2. Determine the proper **drilling location** for the 1" NPT Coupling so that it will be aligned with the Pipe Nipple (Refer to Drawing on Next Page). Couplings shown for guide cables, optional per assembly.
3. One of the two vertical Pipe Nipples probably needs to be shortened so that the Reeving Assembly will be at the correct height to mate with the 1" NPT Coupling. Also, the horizontal Pipe Nipple can be shortened if desired. Determine the **cut lengths** of any Pipe Nipples to be cut.

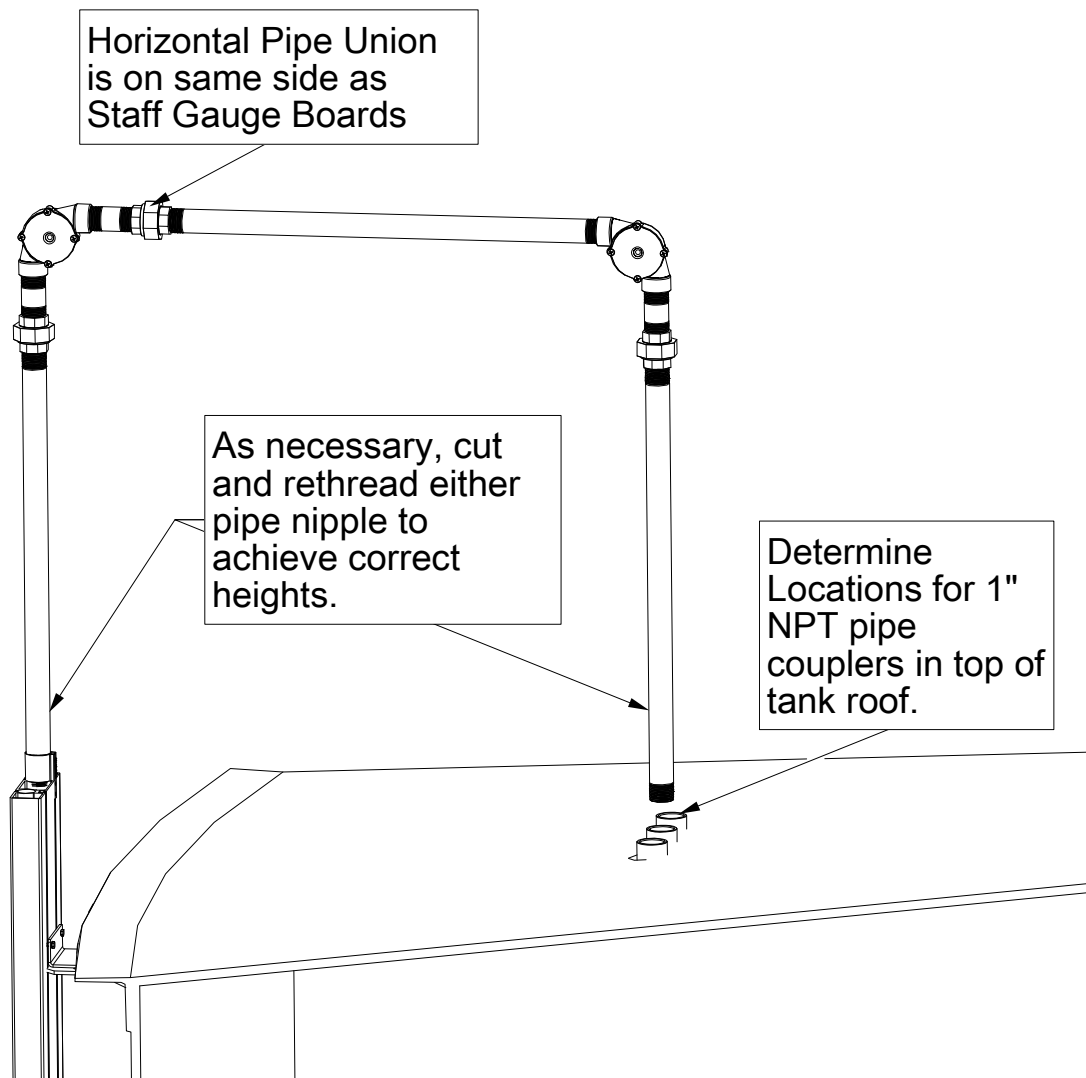

Detach the Reeving Assembly. Bring the Reeving Assembly **and Adapter** to the ground. Cut and re-thread any Pipe Nipples that need to be shortened.

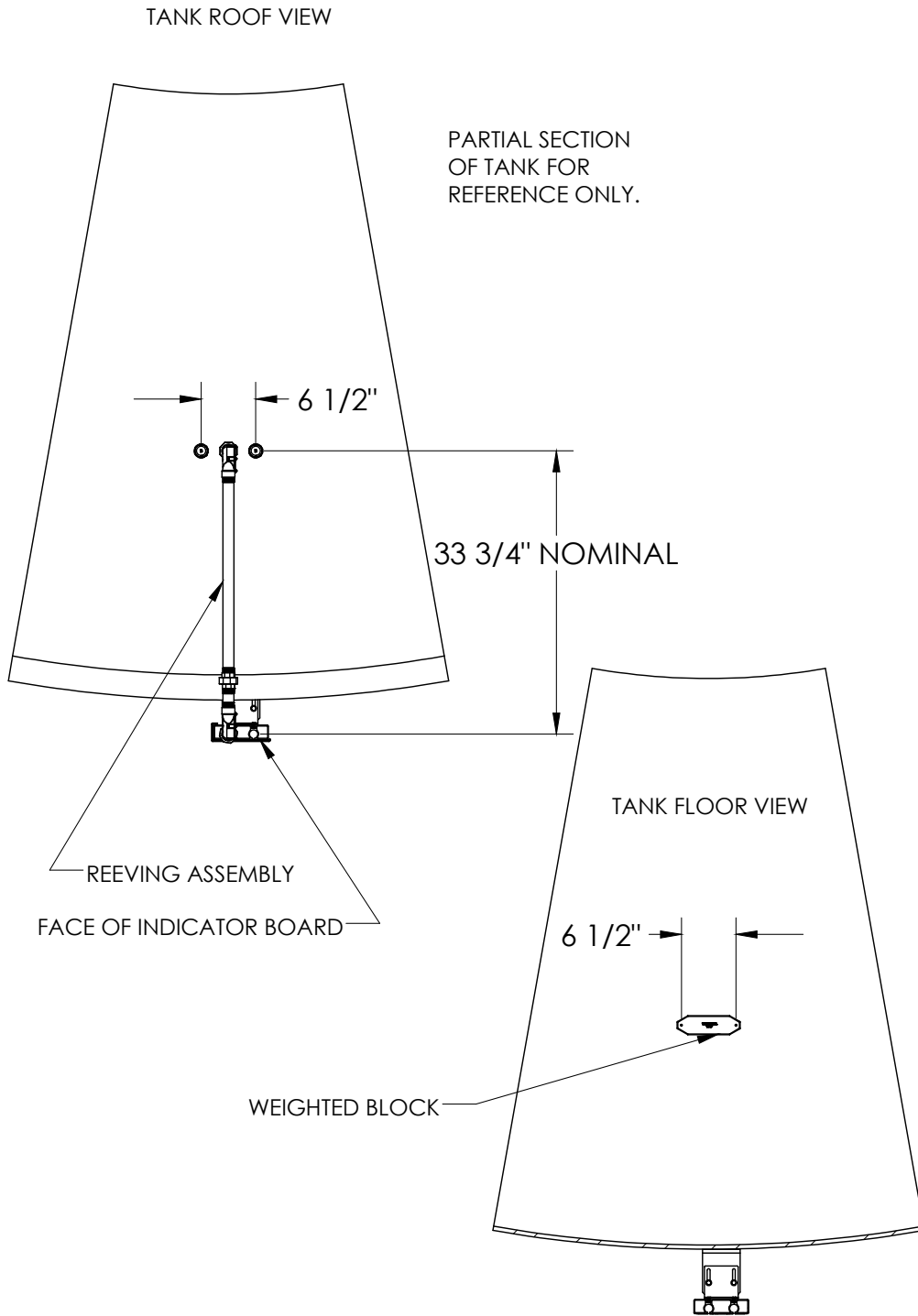

STEP G – 1: Install 1” NPT Couplers to Tank Roof.

2: Install Guide Cable Tension Assemblies

1. Install onto the roof of the tank the 1” NPT Coupling. If Guide Cables are to be used, then also install the two Guide Cable Tension Assemblies. The Guide Cable Tension Assemblies should be located so that the 1” NPT Coupling is at the midpoint. Refer to the diagram on the previous page.

The Guide Cables will be installed in a later step.

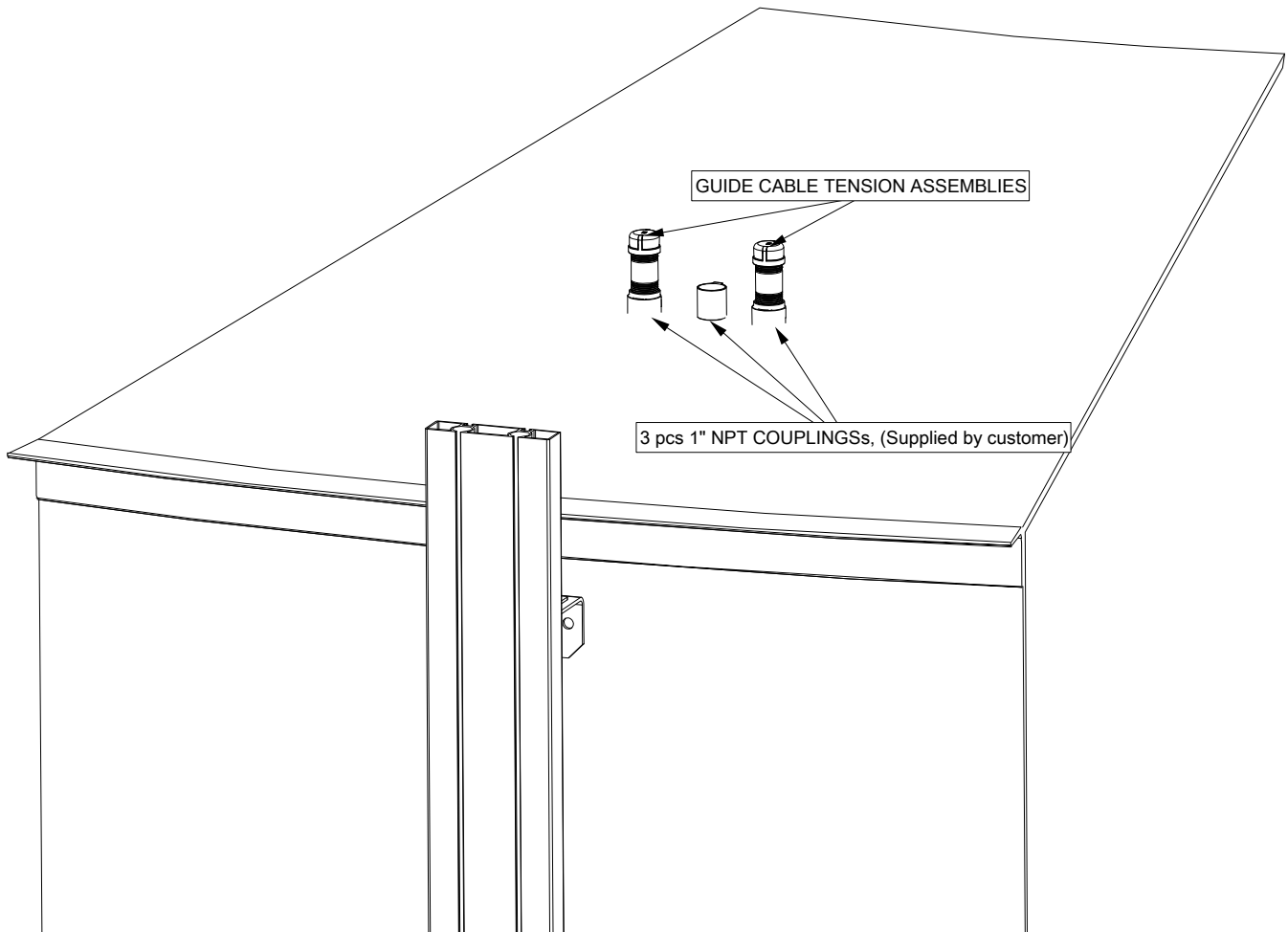

1. Prepare Reeving Assembly for installation

Unscrew the Unions of the Reeving Assembly. Feed the Float Cable through each of the four components of the Reeving assembly. Then feed the cable through the Sleeve Insert (optional) and the Adapter. With the Cable Clamp attached to the Target, loosen the set screws on the Cable Clamp and insert the Float Cable. Tighten the lower set screw, pull-test the cable, and then tighten the upper set screw.

Attach the unions, and loosely attach the Adapter to the Pipe Nipple. Coil the excess Float Cable on the side opposite to the target. Secure the Target to the adapter and excess Float Cable to the Pipe Nipple with masking tape.

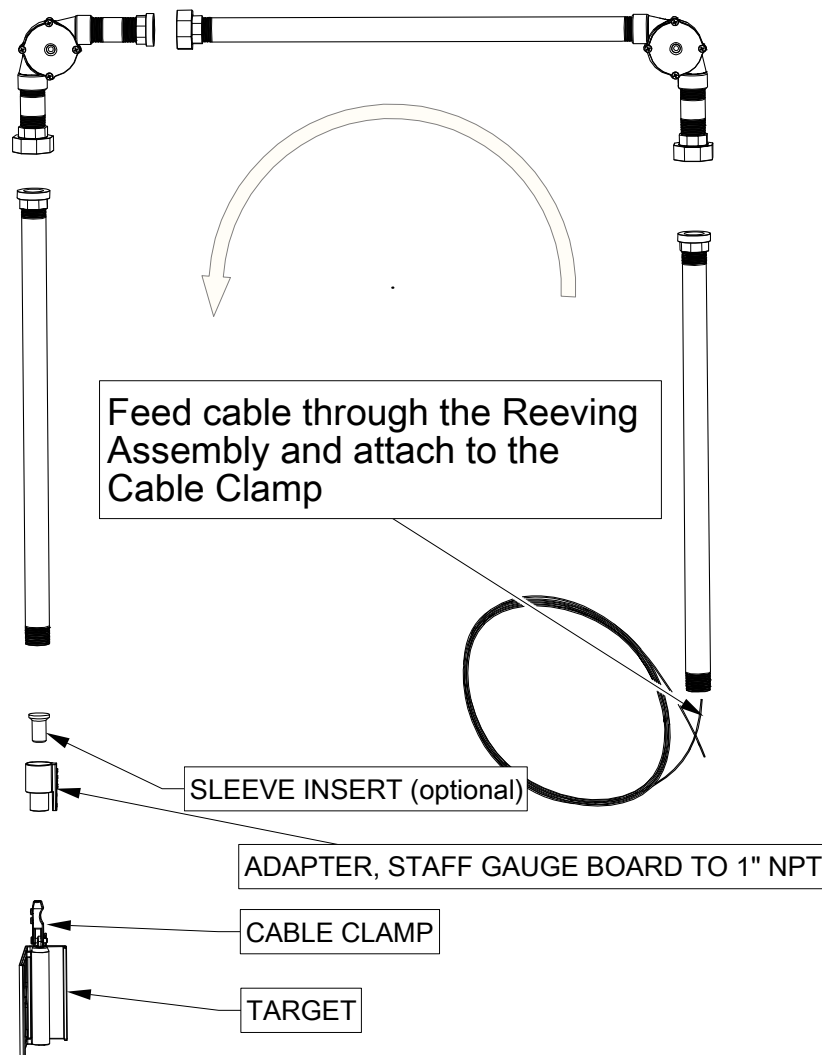

2. Install the Reeving Assembly

Carry the Reeving Assembly to the tank roof with the Float Cable inside, and the Target attached.

Insert the black Camming Tab into the left tube of the Staff Gauge Board channel, about 12" below the top of the Staff Gauge Board, and twist gently until it stays in-place. Insert the Target into the channel so that the Target securely rests on top of the Camming Tab. Mount the Reeving Assembly on top of the Staff Gauge Board. Tighten the Pipe Nipple into the Adapter, and tighten the set screws on the Adapter.

Ensure that the Target rests on top of the Camming Tab until the Float is attached. Otherwise, the Target may fall and pull the Float Cable out, as well as potentially break the target.

Feed the excess Float Cable through the middle 1" NPT coupler installed on the tank roof. Now tighten the Pipe Nipple into the 1" NPT coupler.

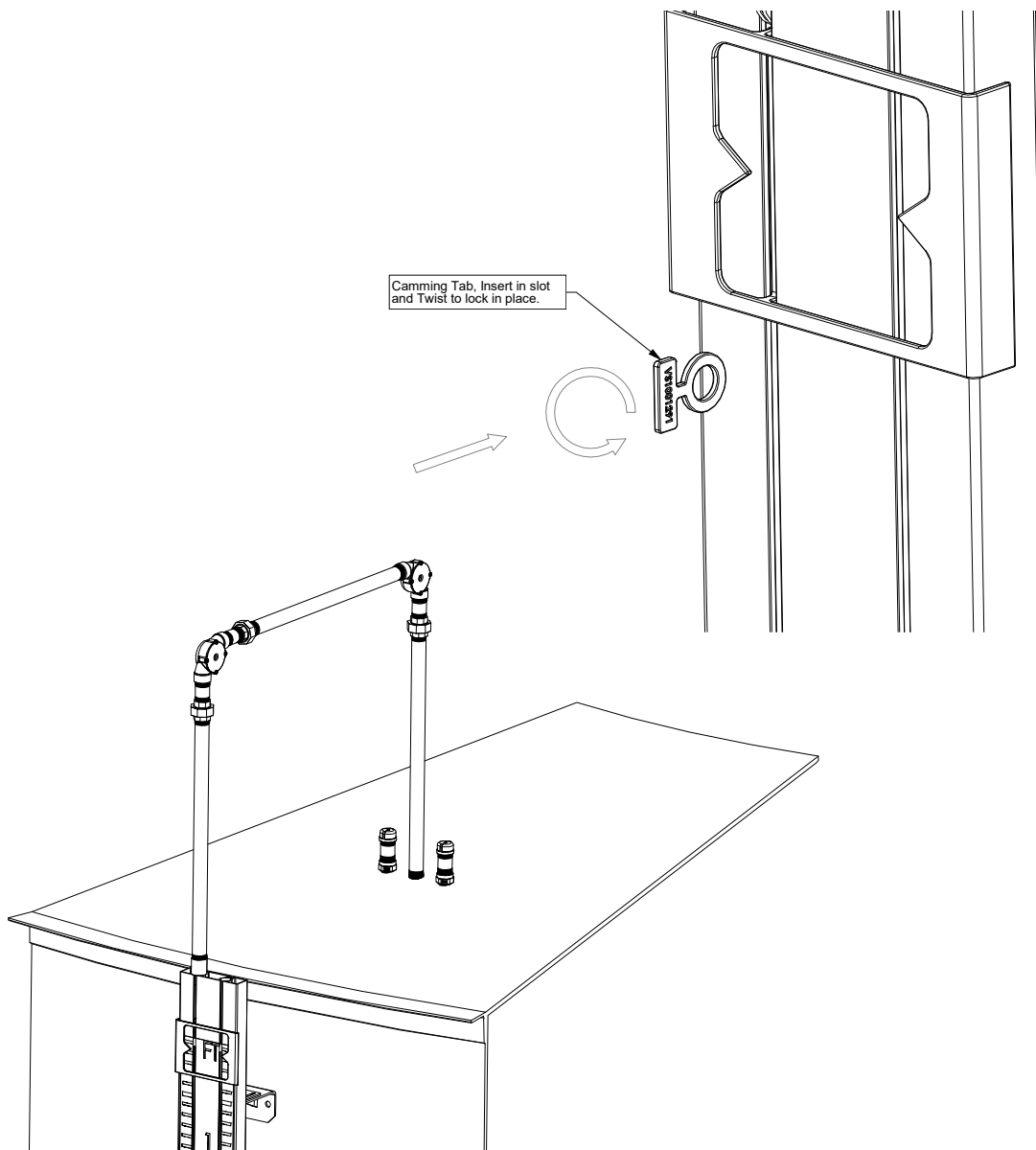

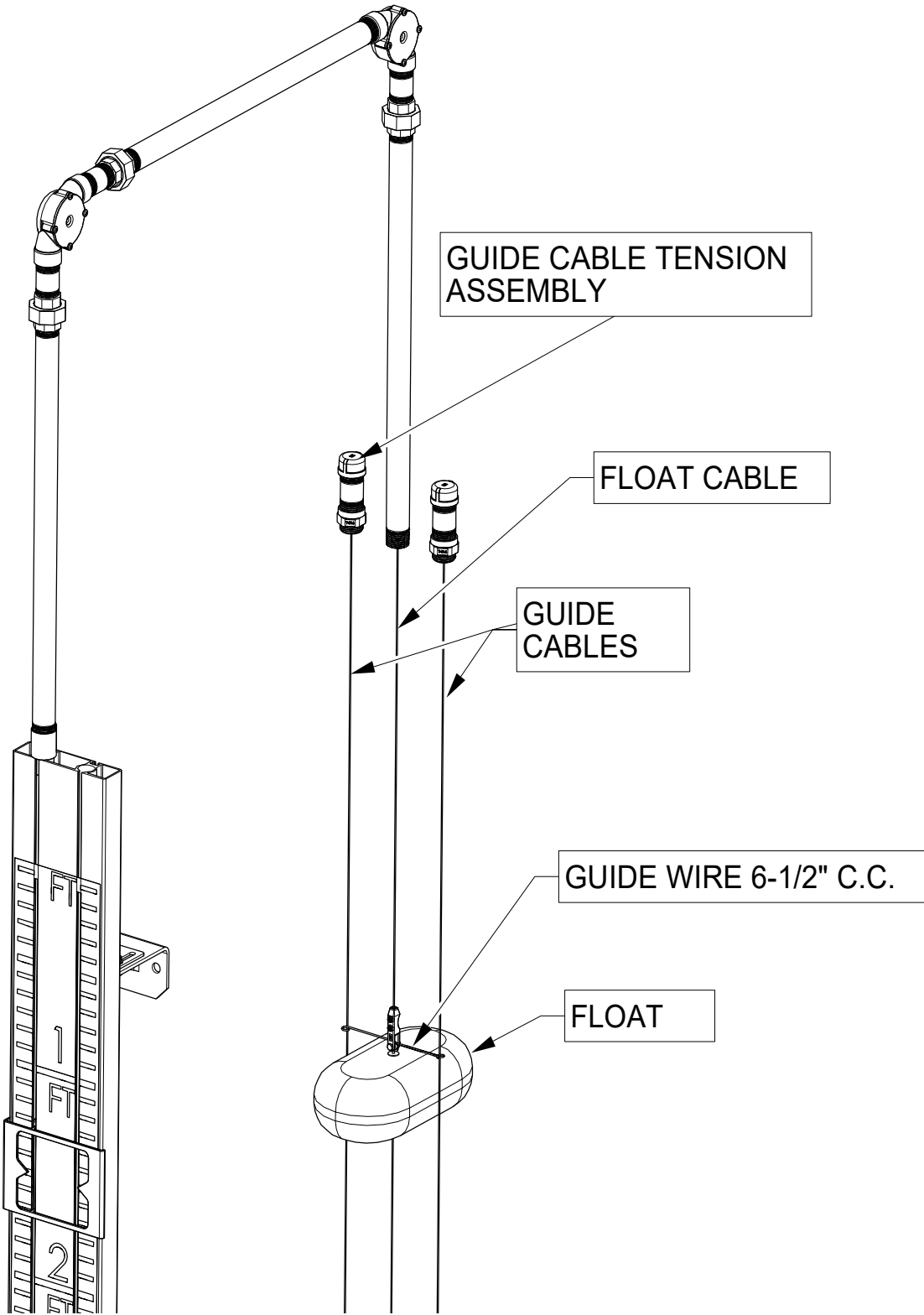

STEP H – Feed the Guide Cables

1. Repeat the following for each of the Guide Cable Tension Assemblies:
2. **Open the Guide Cable Tension Assembly. Remove the Locking Collar together with the attached Conical Spring. Feed the Guide Cable down through the Shoulder Bushing. Loosen the two set screws and feed about 1' of the Guide Cable through the Conical Spring and Locking Collar. Loosely tie an overhand knot as a stopper, and temporarily tighten the set screws. The stopper knot will help later to prevent the Guide Cable from falling down when the set screws are loosened for tensioning. Leave the Guide Cable Tension Assemblies open until after tensioning in a later step.**

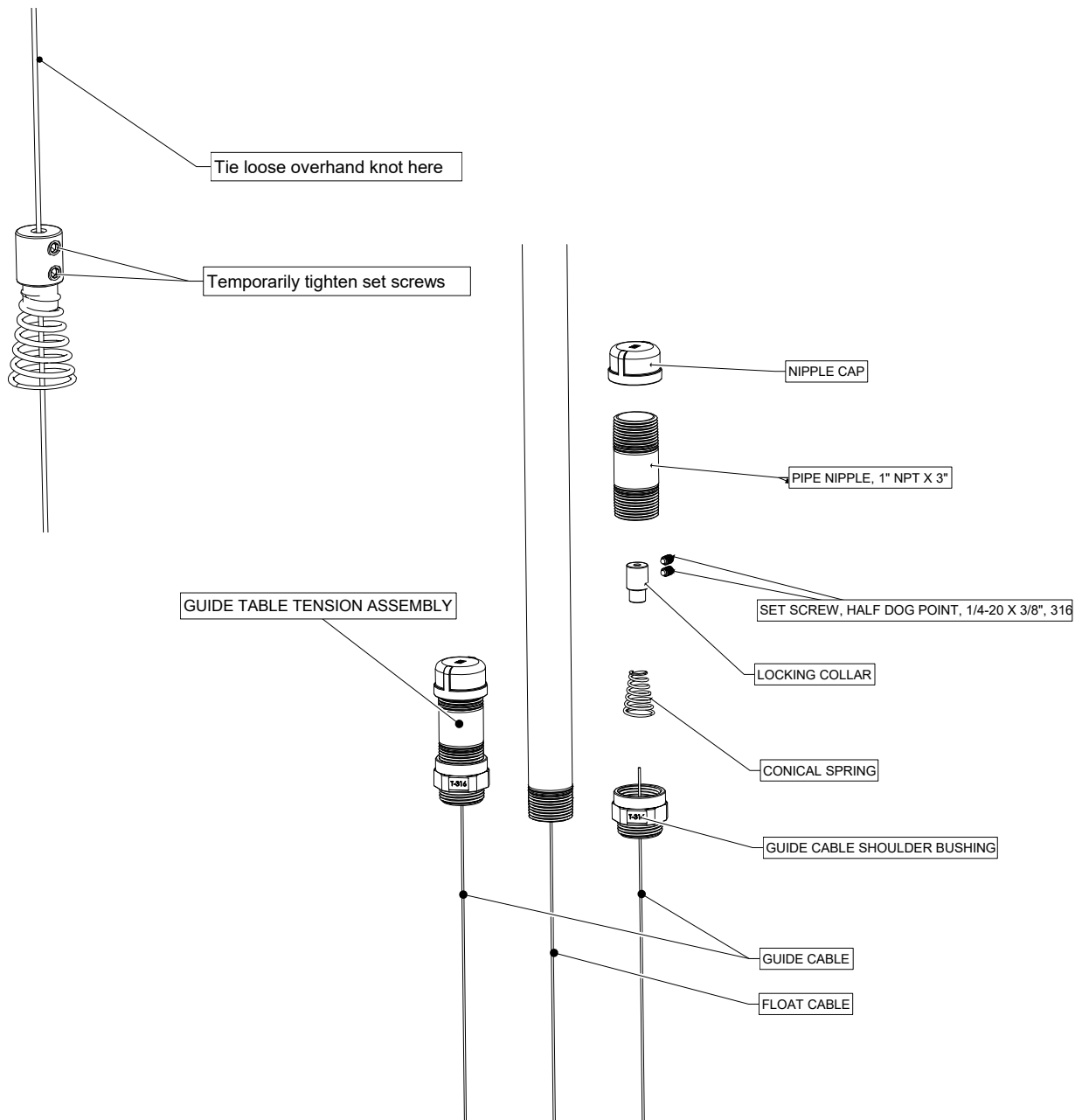

STEP I – Attach Float, Guide Cables, and Weighted Block

1. Attach the Float Cable to the Float via the Cable Clamp. (Tighten the lower set screw, pull-test, then tighten the upper set screw.) If using guide cables, feed the Float Guide Cables through the Guide Wire mounted on Float.

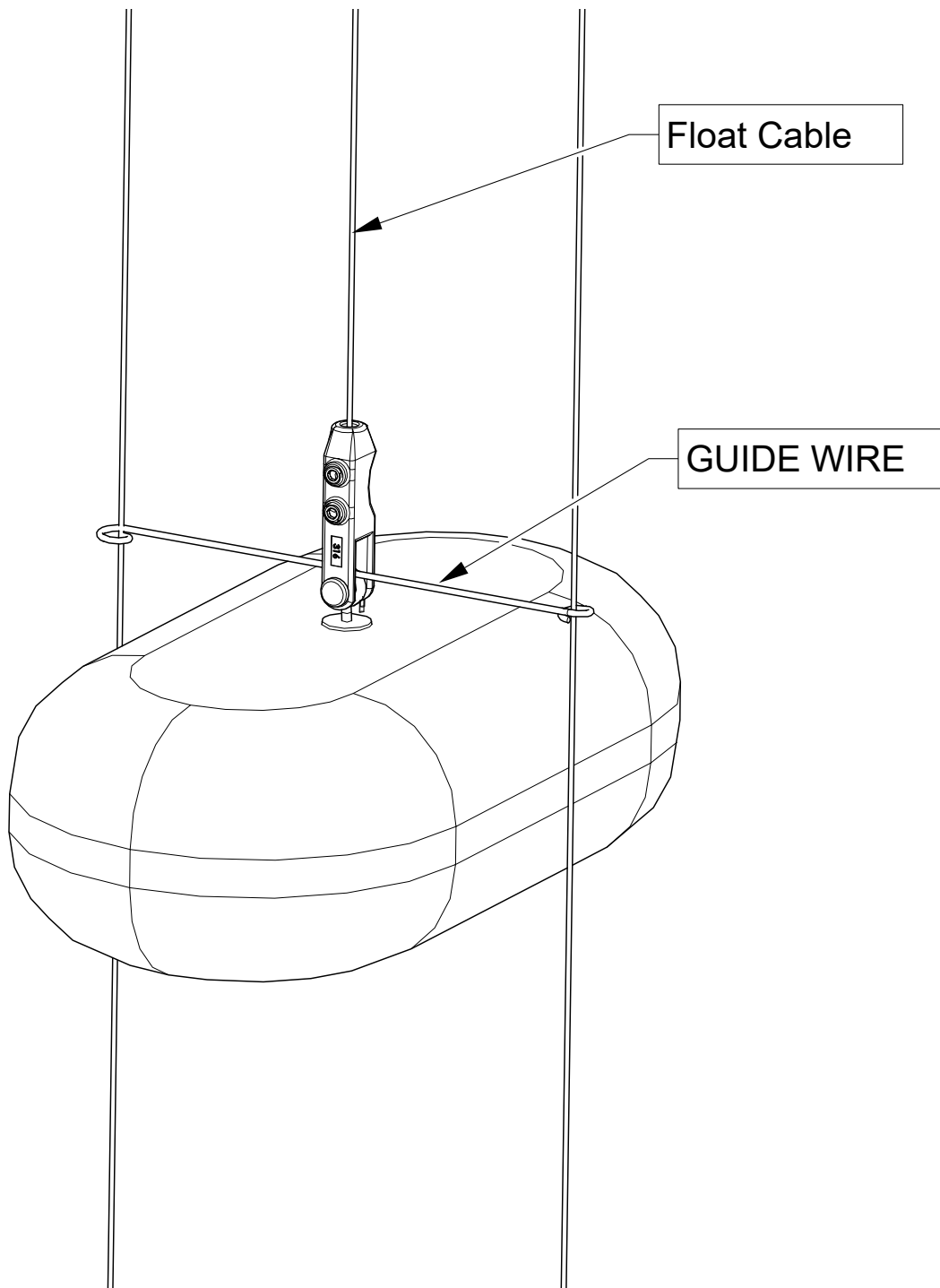

STEP K

1. The Weighted Block can be secured to the tank floor while the tank is empty. One method is by welding. The holes in the block should line up with the Cable Tension Assembly on roof of the tank. These holes are 6-1/2" apart and are positioned in line with the Float. A plumb-bob may be used for accurate locating. Although we always recommend securing to the floor of the tank, the block is heavy enough to stay in position without welding if no agitators are inside the tank.

Note: If the tank currently has liquid inside, the Weighted Block and Float Guide Cable assemblies can be lowered into the tank.

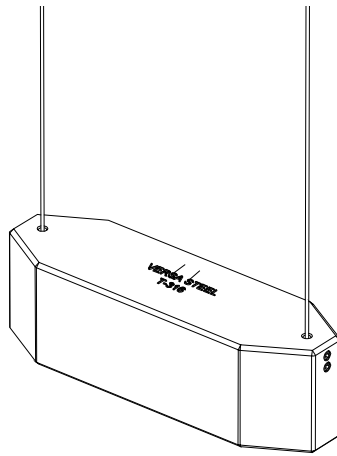

STEP L

A – Tension Guide Cables on an Empty Tank

1. From the roof of the tank, on each Guide Cable Tension Assembly, loosen the set screws on the locking collar. Use a stopper knot to ensure that the Guide Cable doesn't fall. Pull up on the Guide Cable to provide tension.
2. Compress the conical spring and locking collar by 3/8" to 1/2". Tighten the locking collar using the two set screws. (Tighten one set screw, pull-test, then tighten the second. Be careful not to over-tighten as this will damage the Float Guide Cable).
3. Undo the stopper knot and install the 3" Threaded Pipe Nipple back onto the base of the Cable Tension Assembly.
4. Cut the excess cable at the top of the 3" Threaded Pipe Nipple.
5. Replace the pipe caps using a sealant that is strong enough to retain the cap, but allowing you to remove it later to adjust tension as required.

B – Tension Guide Cables on a Live Tank

1. Pull up on the Float Guide Cable until there is no slack and cable is taut.
2. *FOLLOW STEPS 3, 4 and 5 ABOVE.*

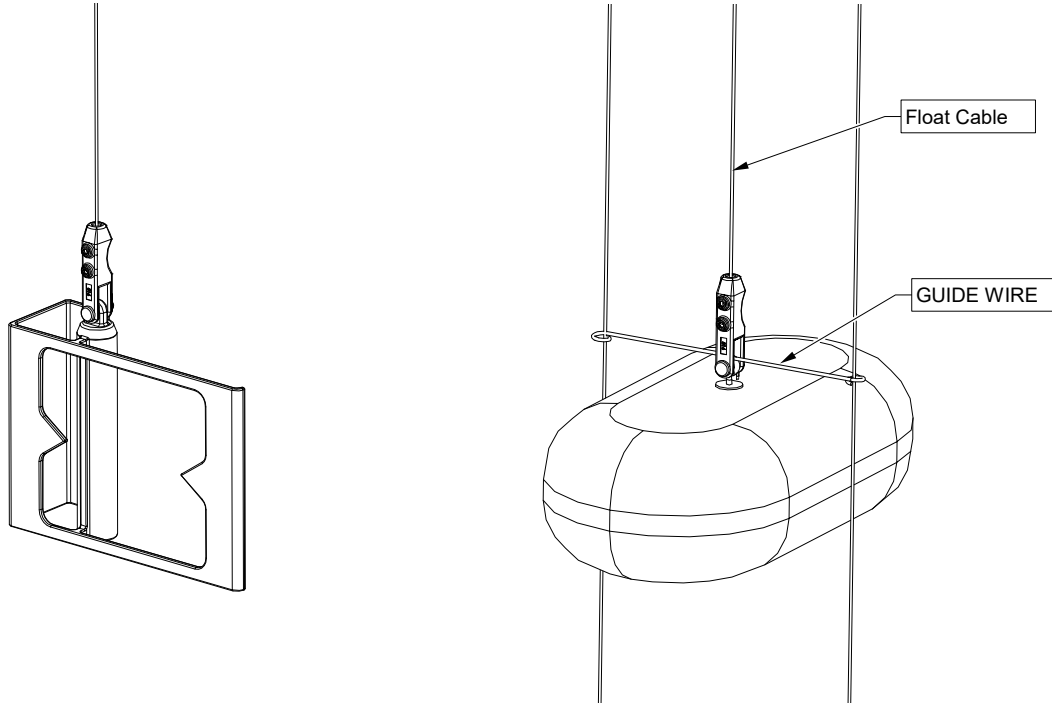

STEP M - Calibrate Target

Two Ways to Calibrate System:

1. Position the Target at 3 ft on the Staff Gauge Board or at a designated height that is easy to measure on the inside of the tank. Use the Camming Tab or tape to hold the Target in place. Have a person inside the tank loosen the two set screws on the Cable Clamp attached to the Float. Remove the slack by pulling the cable through the Cable Clamp and out past the Float. Now adjust the Float so that the equator is 3 ft off of the tank floor (or at the designated height) and retighten the set screws. Test by releasing the Target and then moving the Float to 5 ft allowing the person outside the tank to confirm correct position of the Target. If this matches then cut the excess cable and your calibration is complete.
2. On a live tank you will need to calibrate from the outside of the tank. First you will need to measure the height of the liquid inside of the tank. Adjust the Target and secure it in place at the height of the liquid inside the tank. Loosen the two set screws on the Cable Clamp attached to the Target and start pulling the excess cable through the hole on the Cable Clamp. During this process make sure there is someone at the roof of the tank watching that you aren't raising the Float from the liquid surface. Now tighten the two set screws on the Cable Clamp and cut the excess cable flush. You have now calibrated your level indicator.

***CONGRATULATIONS, YOU ARE NOW DONE INSTALLING A
TROUBLE FREE TANK LEVEL INDICATOR FROM VERSA-STEEL
INC.!***